

# National Policy Statement for Renewable Electricity Generation Technical Guide

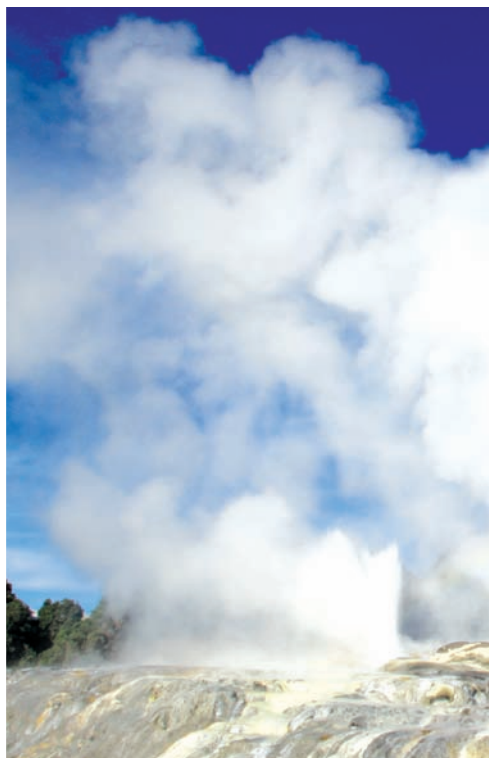

# National Policy Statement for Renewable Electricity Generation

## Contents

---

<b>Introduction</b>	<b>4</b>
<b>INTRODUCTION TO RENEWABLE ELECTRICITY IN NEW ZEALAND</b>	<b>5</b>
<b>1. New Zealand electricity industry</b>	<b>6</b>
1.1. Introduction	6
1.2. Electricity industry overview	6
1.3. Renewable electricity generation	6
1.4. Electricity market overview	8
1.5. Generation and retail	9
1.6. Transmission	9
1.7. Distribution	10
1.8. Electricity Authority	10
1.9. Commerce Commission	11
1.10. The Ministry of Business, Innovation and Employment	11
1.11. Energy Efficiency and Conservation Authority	11
1.12. Ministry for the Environment	11
1.13. Environmental Protection Agency	11
1.14. Local government	12
<b>2. Meeting demand and the renewable electricity generation target</b>	<b>13</b>
2.1. Background	13
2.2. Path to 2025	13
<b>3. Renewable electricity generation technologies</b>	<b>15</b>
3.1. Hydro	15
3.2. Geothermal	19
3.3. Wind	24
3.4. Biomass	26
3.5. Solar	28
3.6. Marine	30
<b>NATIONAL POLICY STATEMENT FOR RENEWABLE ELECTRICITY GENERATION – TECHNICAL INFORMATION ON POLICIES</b>	<b>32</b>
<b>4. Policy A: Benefits of renewables</b>	<b>33</b>
<b>5. Policy B: Practical implications</b>	<b>40</b>
<b>6. Policy C: Practical constraints</b>	<b>42</b>
<b>7. Policy D: Managing reverse sensitivity effects</b>	<b>49</b>
<b>8. Policy F: Small and community-scale electricity generation</b>	<b>50</b>
<b>9. Policy G: Enabling identification of renewable electricity generation possibilities</b>	<b>52</b>
<b>10. Glossary</b>	<b>54</b>
<b>11. References</b>	<b>56</b>

## LIST OF FIGURES

Figure 1	New Zealand's renewable electricity generation	7
Figure 2	New Zealand Electricity industry	8
Figure 3	Proportion of electricity from renewable energy sources	14
Figure 4	Components of a hydro-electricity scheme	16
Figure 5	Manapouri hydro-electricity power station, Southland	16
Figure 6	Nga Awa Purua geothermal power station, Taupō	19
Figure 7	Single flash steam geothermal power station	21
Figure 8	Binary geothermal power station	21
Figure 9	Rotokawa geothermal power station, Taupō	22
Figure 10	Wairakei Terraces, Taupō	22
Figure 11	Components of a wind turbine	24
Figure 12	Tararua wind farm, Manawatu	25
Figure 13	Hau Nui wind farm, Wairarapa	25
Figure 14	Biomass feedstock (wood chips)	26
Figure 15	Roof-mounted PV array	28
Figure 16	Ground-mounted PV array, Drury, Auckland	29
Figure 17	Prototype marine energy device, Wellington Harbour	30
Figure 18	Electricity generation in New Zealand by fuel type	34
Figure 19	Lake Pukaki (Waitaki River hydro-electricity scheme)	36
Figure 20	Ngāwhā geothermal power station, Northland	37
Figure 21	Project West Wind, Wellington	38
Figure 22	Biomass feedstock storage	39
Figure 23	Roof-mounted PV array	39
Figure 24	Electricity output process	40
Figure 25	Motukawa hydro-electricity scheme, Taranaki	41
Figure 26	Benmore power station, Waitaki hydro-electricity scheme	44
Figure 27	Tokaanu power station, Tongariro hydro-electricity scheme	46
Figure 28	Wairakei geothermal power station, Taupō	46
Figure 29	Weld Cone wind farm, Marlborough	50
Figure 30	Talla Burn hydro scheme, Central Otago	51
Figure 31	Geothermal drilling rig	52
Figure 32	Wind monitoring mast	53

*The information in this document is provided in good faith, and is not intended to be treated as mandatory. This guide is not a substitute for professional advice.*

*EECA wishes to acknowledge the valuable contributions made to the development of this document by a range of stakeholders. In particular: Sinclair Knight Mertz, Aurecon, Contact Energy, Genesis Energy, Meridian Energy, Mighty River Power and TrustPower along with AWATEA, BANZ, GNS Science, NZGA, NZWEA and SEANZ.*

*This document may be updated from time to time. The latest version is available from the EECA website ([www.eeca.govt.nz](http://www.eeca.govt.nz)).*

# Introduction

## Purpose of the Technical Guide

---

The National Policy Statement for Renewable Electricity Generation (NPS REG)<sup>1</sup> was gazetted on 14 April 2011. It was developed to support the Government's target that '90 percent of electricity generation be from renewable sources by 2025 (in an average hydrological year) providing this does not affect security of supply'.<sup>2</sup>

This document is intended to assist the implementation of the NPS REG by providing an explanation of the technical terms and concepts used in the NPS REG. It is intended for use mainly by local government decision makers, but also the general public.

## Structure of the Technical Guide

---

This guide is structured in two parts:

### **Introduction to Renewable Electricity in New Zealand**

- overview of the New Zealand electricity system and market
- explanation of the renewable electricity target – 90% by 2025
- summary of the most common types of renewable electricity generation technologies

### **Technical Information on NPS Policies**

- explanation of technical elements of Policies with examples (excluding Policy E)
- glossary of technical terminology.

## Scope of the Technical Guide

---

The purpose of this guide is to explain technical terms and concepts associated with the NPS REG. It does **not** provide guidance on the environmental effects of renewable electricity generation activities that can span local, regional and national scales other than in association with the day to day operation and maintenance of REG activities.

The Technical Guide does not explicitly address Policy E (Incorporating provisions for renewable electricity generation activities into regional policy statements and regional and district plans) however the guidance on common types of renewable electricity generation technologies should provide background to assist local authorities to give effect to this policy.

This guidance should be read in conjunction with the Ministry for the Environment NPS REG Implementation Guide which is available from their website<sup>3</sup> and which provides local authorities with direction on how to implement the NPS REG in their policy statements and plans and includes example planning provisions.

1 [www.mfe.govt.nz/rma/central/nps/generation.html](http://www.mfe.govt.nz/rma/central/nps/generation.html)

2 *The New Zealand Energy Strategy 2011–2021*, p6. [www.med.govt.nz/energy-strategy](http://www.med.govt.nz/energy-strategy)

3 [www.mfe.govt.nz/rma/central/nps/generation.html](http://www.mfe.govt.nz/rma/central/nps/generation.html)



# Introduction to Renewable Electricity in New Zealand

# 1. New Zealand electricity industry

## 1.1. Introduction

---

This document provides an introduction to renewable electricity in New Zealand. Renewable electricity utilises energy produced from solar, wind, hydro, geothermal, biomass, tidal, wave and ocean current sources.<sup>4</sup>

It gives an overview of the main components of New Zealand's electricity system and market. Within this context it also explains the renewable electricity target that 90% of New Zealand's electricity will be from renewable sources by 2025 providing it does not compromise security of supply. This target is contained within the 2011 New Zealand Energy Strategy.

This document also summarises the key characteristics of the most common types of renewable electricity generation technologies and explains relevant technical concepts. It does not provide information on the environmental effects of renewable electricity generation activities that can span local, regional and national scales other than in association with the day-to-day operation and maintenance of renewable electricity generation activities.

## 1.2. Electricity industry overview

---

The electricity industry has the following main components:

- generation (electricity production companies that produce and sell electricity generally at the wholesale level)
- retail (companies that buy wholesale electricity and sell it to consumers)
- transmission (transport of electricity from power generation facilities to load centres via the high voltage network known as the national grid)
- distribution (transport of electricity to consumers by local electricity lines companies).

The generation and retail components of the electricity industry operate within a competitive market-based system. The transmission and distribution systems are natural monopolies that are regulated particularly to maintain an oversight of costs and ensure an appropriate level of service to consumers. A number of government agencies have a role in the industry through electricity market policy and regulatory functions.

## 1.3. Renewable electricity generation

---

New Zealand's electricity is generated using a diverse range of energy sources utilising both renewable resources (e.g. hydro, geothermal and wind) and non-renewable sources also referred to as fossil fuel (e.g. gas and coal). New Zealand has historically generated a high proportion of its electricity from renewable sources, and has relied heavily on hydro with fossil fuel resources also being used. Recently the proportions of energy generated using wind and geothermal have increased. Figure 1 shows the location of New Zealand's renewable electricity generation.

Figure 1 New Zealand's renewable electricity generation 2012

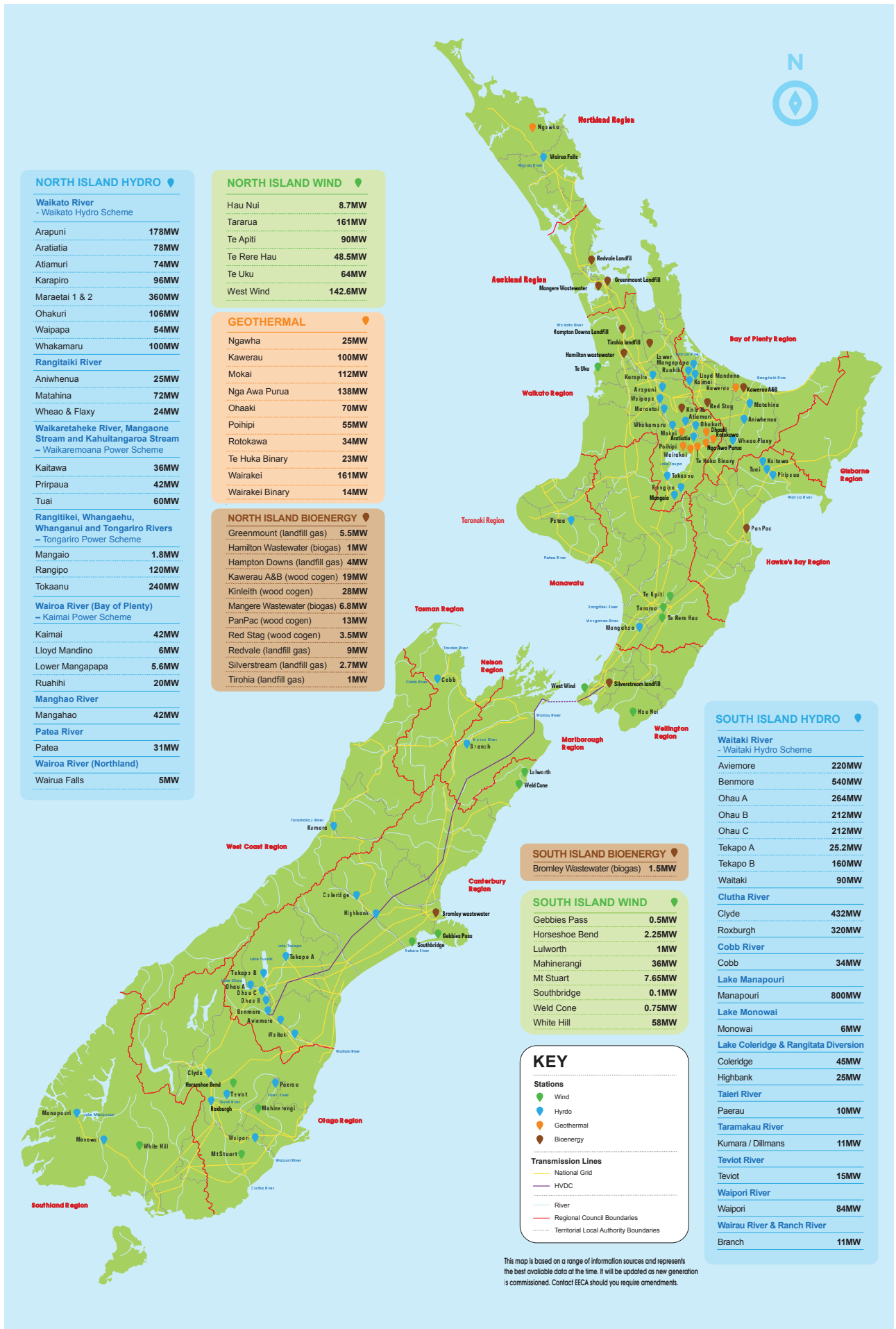

(Source: prepared by Base Two Limited for EECA)

Once generated, electricity is transported around the country by the Transpower-owned and operated national grid. It is then delivered locally to final consumers by lines companies (also called distribution companies), which operate the local electricity distribution network. Retailers are companies that purchase electricity from the wholesale market and sell it to consumers.

A small number of large industrial consumers such as steel, aluminium and wood processors are directly connected to the national grid and some of these also use electricity generated on their premises (known as on-site generation). A small proportion of electricity is also supplied from generation which links directly into local distribution company networks and is not connected to the national grid. This is usually referred to as 'embedded generation' and is commonly of a smaller scale than generation connected to the national grid.

Figure 2 shows a simple representation of New Zealand's electricity industry.

Figure 2 New Zealand Electricity industry

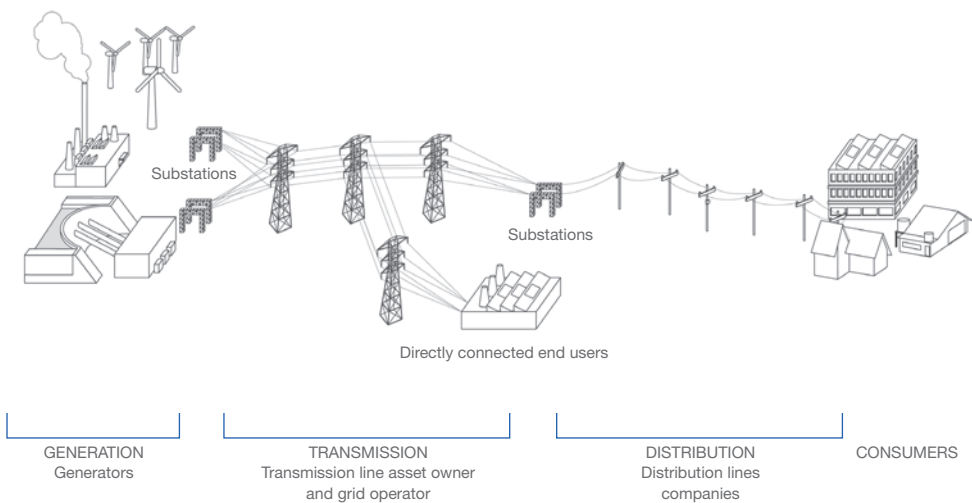

(Source: EECA)

## 1.4. Electricity market overview

The electricity market in New Zealand is open to any electricity generator or retailer to participate in. It is a competitive market based around market rules developed by the industry and government. Electricity market policy and regulatory structure functions are carried out by three main government bodies: the Economic Development Group of the Ministry of Business, Innovation and Employment (MBIE), the Electricity Authority and the Commerce Commission. Information on these agencies and the different components of the electricity system and other agencies that have energy-related functions is provided later in this chapter.

The wholesale electricity market provides the structure for:

- managing security of supply such that electricity supply and demand are matched at all times
- providing efficient prices to signal the current and forecast cost of electricity including transmission losses and constraints, and costs associated with ensuring security of electricity supply
- market participants (generators and purchasers) that trade electricity.



## 1.5. Generation and retail

---

Electricity generators offer a certain quantity of electricity at a certain price (and at a certain location) into the wholesale market every half hour, while the purchasers (retailers and some directly connected industrial users) nominate their anticipated electricity demand. The price of the electricity for each half hour is set by stacking up the offers from the lowest price until the demand is met. Some 'must-run' electricity generation<sup>5</sup> is offered at a very low or zero price so that it is taken up, but all successful offers receive the price of the most expensive electricity required (i.e. the top offer of the stack). This is termed marginal-cost pricing.

The settlement price or electricity 'spot' price varies with changes in supply and demand. Various longer term contractual mechanisms (hedges) are employed by market participants to manage the variability of electricity prices.

There are five large generator companies and a number of smaller companies generating electricity in New Zealand. The five large generator companies that supply the wholesale market are:

- **Contact Energy** [www.contactenergy.co.nz](http://www.contactenergy.co.nz)
- **Genesis Power** [www.genesisenergy.co.nz](http://www.genesisenergy.co.nz)
- **Meridian Energy** [www.meridianenergy.co.nz](http://www.meridianenergy.co.nz)
- **Mighty River Power** [www.mightyriver.co.nz](http://www.mightyriver.co.nz)
- **TrustPower** [www.trustpower.co.nz](http://www.trustpower.co.nz)

Electricity generators can also act as retailers, with the five large generators also being large retailers along with a number of smaller companies.

The retailers purchase electricity from the wholesale market and sell it to individual customers. The customers range from small households to large industrial users. Distribution companies can also be generators and retailers (though with certain restrictions, to avoid monopoly behaviour).

The retail component of the electricity market is made up of a number of complex processes that deal with accuracy of metering, meter reading, switching of consumers between retailers, allocation of volumes of electricity to consumers and billing consumers. Some retailers use a number of electricity meters to measure the consumption of electricity on different rates: anytime rate; water heating rate; night rate. It is the retailer's responsibility to ensure meters are available at points of connection between the customer and local network. In New Zealand, metering services are provided by competing metering equipment providers that provide metering services to retailers, distributors and other parties.

## 1.6. Transmission

---

The majority of New Zealand's electricity is generated at remote locations and requires an efficient transmission system to transport it to the main centres.

Transpower is the State-Owned Enterprise (SOE) that owns and operates the national grid.<sup>6</sup> This high voltage transmission system enables competition in the electricity market by providing consumers (wherever they are) access to the lowest cost generation at any particular time. The national grid covers the length of New Zealand, consisting of around 12,000 km of transmission lines (electricity power lines) and 182 substations and switchyards where voltage is managed to allow electricity to be moved efficiently. Over 50 power stations supply electricity to the national grid.

Transpower's power lines operate at voltages of 50 kilovolts and above, and include the high voltage direct current (HVDC) lines that connect Benmore in the South Island's Waitaki Valley with the North Island at Haywards just north of Wellington. When electricity is transmitted at high voltage, there is less electricity loss from resistance. This is why higher voltages are used for the national grid, which transmits more power over longer distances compared to local distribution lines companies that generally use lower voltages for electricity distribution.

<sup>5</sup> 'Must-run' generation typically includes geothermal, wind and run-of-river hydro-electricity generation. It can also include a material amount of fossil fuel generation; this is because it is generally preferable to keep coal and combined cycle gas fired generation operating, rather than having to stop and start too often (stop/start operation causes higher overall generation costs for fossil fuel plant).

<sup>6</sup> Further information about Transpower is available online at [www.transpower.co.nz](http://www.transpower.co.nz)

As grid owner, Transpower manages the assets that transmit electricity around the country (high voltage lines and pylons along with other electrical equipment necessary for the national grid such as substations and transformers). In this role, Transpower undertakes condition monitoring and maintenance of existing grid assets and planning and installation of new grid assets. As system operator, Transpower also manages the operation of New Zealand's power system ensuring the appropriate quantity and quality of electricity supply in real time.

A National Policy Statement on Electricity Transmission (2008) requires recognition of the national significance of the national grid in regional policy statements and plans and in resource consent decision making.

## 1.7. Distribution

---

Distribution companies – also called electricity lines companies – own and manage the local distribution lines that bring electricity to consumers from substations on the national grid. The distribution network consists of medium and low voltage (typically less than 50 kilovolt) power lines, substations and transformers.

While the majority of consumers receive their electricity from their local distribution network, a few large users are connected directly to the national grid or from generation connected directly to the local network. While the majority of generation conveyed by distribution networks is sourced from Transpower substations, they may also source some electricity directly from small generators who connect into the distribution network. This is known as embedded generation (i.e. embedded within a distribution network, or even within a local business).

There are currently 29 local lines companies across New Zealand.<sup>7</sup> Most lines companies are owned by trusts but the ownership mix also includes public listings, shareholder co-operatives, community trusts and local bodies.

## 1.8. Electricity Authority

---

The Electricity Authority is the independent regulator with the objective “to promote competition in, reliable supply by, and the efficient operation of, the electricity industry for the long-term benefit of consumers”.<sup>8</sup> The key functions of the Electricity Authority are:

- registering industry participants and maintaining a database of information on all electricity industry participants and connection points
- developing, administering, and enforcing the Electricity Industry Participation Code 2010
- facilitating market performance through information, best-practice guidelines and related services
- undertaking sector reviews
- acting as market administrator and contracting market operation service providers
- promoting consumer switching
- monitoring electricity sector performance against the Authority's statutory objective.

<sup>7</sup> Details of the regions covered by local distribution lines companies are available online at [www.electricity.org.nz](http://www.electricity.org.nz)

<sup>8</sup> Further information on the Electricity Authority is available online at [www.ea.govt.nz/about-us](http://www.ea.govt.nz/about-us). The Electricity Authority replaced the Electricity Commission in 2010 following changes to the industry made by the Electricity Industry Participation Act 2010.

## 1.9. Commerce Commission

---

The Commerce Commission is New Zealand's primary competition regulatory agency.<sup>9</sup> It is an independent Crown entity and is not subject to direction from the Government in carrying out its enforcement and regulatory control activities. In the electricity sector, the Commerce Commission acts as a body that regulates the monopoly operators, Transpower and lines companies. For example, the Commerce Commission regulates the price of transmission charged by Transpower. The electricity industry is also subject to the provisions of the Commerce Act 1986, the Fair Trading Act 1986 and the Consumer Guarantees Act 1993.

## 1.10. The Ministry of Business, Innovation and Employment

---

The Economic Development Group of the Ministry of Business, Innovation and Employment (MBIE) develops and implements electricity sector policy, particularly relating to the governance and market structure.<sup>10</sup> It also monitors market performance, including competition issues and electricity prices. MBIE's wider role is to lead the production and co-ordination of policy advice related to economic, regional and industry development and is also the Government's primary advisor on the operation and regulation of specific markets and industries.

## 1.11. Energy Efficiency and Conservation Authority

---

The Energy Efficiency and Conservation Authority (EECA) is a Crown entity established by the Energy Efficiency and Conservation Act 2000. EECA's statutory mandate is to encourage, promote and support energy efficiency, energy conservation and the use of renewable sources of energy. EECA is one of a number of agencies implementing aspects of the Government's energy policy particularly in the areas related to energy efficiency, energy conservation and renewable energy. EECA works across all sectors of the economy. EECA's activities are aimed at maximising the benefits arising from energy efficiency and renewable energy to New Zealand.

## 1.12. Ministry for the Environment

---

The Ministry for the Environment (MfE) is involved in the energy sector, primarily in relation to managing adverse environmental effects of electricity generation (e.g. air quality and greenhouse gas emissions).<sup>11</sup> The Ministry administers the Resource Management Act 1991 (RMA) and developed the NPS REG and the supporting Implementation Guide. MfE also leads the Government's climate change policy development.

## 1.13. Environmental Protection Agency

---

The Environmental Protection Authority (EPA) is responsible for administering and making recommendations to the Minister for the Environment on proposals of national significance under the RMA.<sup>12</sup> These may include renewable energy projects. The RMA allows the Minister for the Environment to intervene in proposals of national significance if requested by an applicant, a council or if the Minister decides to intervene.

<sup>9</sup> Further information is available online at [www.comcom.govt.nz/electricity](http://www.comcom.govt.nz/electricity)

<sup>10</sup> Further information is available online at [www.med.govt.nz/sectors-industries/energy/electricity](http://www.med.govt.nz/sectors-industries/energy/electricity)

<sup>11</sup> Further information is available online at [www.mfe.govt.nz](http://www.mfe.govt.nz)

<sup>12</sup> Further information is available online at [www.epa.govt.nz](http://www.epa.govt.nz)

## 1.14. Local government

---

Local government is responsible for the sustainable management of natural and physical resources under the RMA.<sup>13</sup>

Regional councils manage the effects of activities on water, the coast, air, soil and geothermal systems from activities such as earthworks, well drilling, work on the bed of a river or lake and water and heat use and discharge. Regional councils are responsible for the preparation of regional policy statements and plans to set the policy framework for environmental management in the region.

Territorial authorities (district and city councils) are responsible for controlling the impacts of land use and development within their district such as noise, visual and amenity impacts. Territorial authorities are responsible for the preparation of district plans. Unitary authorities carry out the combined role of a regional council and a territorial authority.

Local government is responsible for the determination of relevant resource consent applications to guide land use and development against the requirement to avoid, remedy or mitigate effects in the achievement of sustainable management. Regional policy statement and regional and district plan provisions (objectives, policies and rules) are all relevant when councils consider whether to grant an application for resource consent.

<sup>13</sup> A list of councils is available online at [www.lgnz.co.nz/lg-sector/maps](http://www.lgnz.co.nz/lg-sector/maps)

## 2. Meeting demand and the renewable electricity generation target

### 2.1. Background

---

A reliable and robust electricity system providing electricity at affordable prices is vital for the New Zealand economy. Over the long term, New Zealand will require more electricity as the population and economy expand, and the electricity system is required to meet this growing demand. Any supply disruption results in high costs for society and the economy.

MBIE regularly carries out modelling of New Zealand's energy supply and demand. Demand growth projections in the New Zealand Energy Outlook consider a range of demand growth rates and scenarios and its reference scenario provides useful information using assumptions of business as usual continuing in terms of broad trends in key economic drivers, policy settings and technology and fuel choices. The 2010 Reference scenario<sup>14</sup> noted that electricity demand growth has been growing at an average rate of 1.6% per annum since 1990. Recently, growth has slowed but is assumed to pick up again and average 1.2% per annum out to 2030.<sup>15</sup>

Despite more efficient use of energy, new electricity generation projects will need to be built. New electricity supply will need to be developed to meet ongoing demand growth, and may be required to replace existing power stations when they retire.

The Government's renewable electricity target is that 90% of electricity be generated from renewable sources by 2025 (based on an average hydrological year)<sup>16</sup> providing this does not affect security of supply. The target is contained within the New Zealand Energy Strategy 2011–2021.<sup>17</sup>

### 2.2. Path to 2025

---

A significant increase in renewable electricity generation is required in order to meet the target while maintaining security of supply. The target was set following the consideration of modelling carried out by EECA, Ministry of Economic Development (now part of MBIE) and the Electricity Commission (now the Electricity Authority) in 2007, indicating that it is challenging but achievable.<sup>18</sup> It used a model that estimates the build timing and type of new electricity generation plants (mainly based on expected demand growth and relative generation costs).

The analysis showed that there is sufficient renewable generation available in New Zealand to meet the target without incurring substantial costs or eroding security of supply.

Figure 3 shows the proportion of New Zealand's electricity that has been supplied by renewable electricity from the 1970's to the present day. This proportion has generally reduced over time due to the addition of new gas-fired generation but has risen in recent years again to sit at around 75%. Within this trend, the percentage of electricity generation that is renewable varies from year to year largely due to variations in rainfall that result in different amounts of hydro generation each year.

<sup>14</sup> Ministry of Economic Development (2010) *New Zealand's Energy Outlook 2010 Reference Scenario*, p6.

<sup>15</sup> Ministry of Economic Development (2011) *New Zealand's Energy Outlook 2011 Reference Scenario*, p6.

<sup>16</sup> This is included because generation from hydro is variable from year to year depending on the amount, timing, and location of rainfall in New Zealand.

<sup>17</sup> *The New Zealand Energy Strategy 2011–2021*, p6. [www.med.govt.nz/energy-strategy](http://www.med.govt.nz/energy-strategy)

<sup>18</sup> Energy Efficiency and Conservation Authority, Ministry of Economic Development, Electricity Commission (2007). *The Implications of Higher Proportions of Renewable Electricity by 2030*. Briefing to the Minister of Energy, David Parker.

Figure 3 Proportion of electricity from renewable energy sources

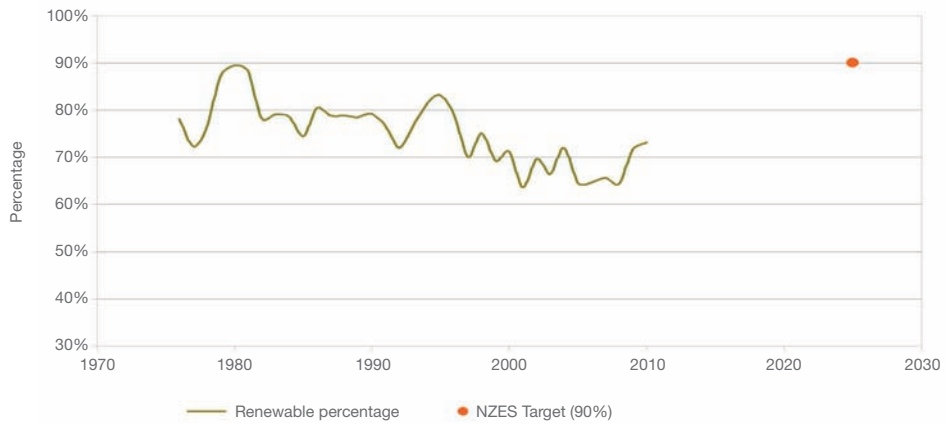

(Source: EECA, adapted from Energy Data File 2011)

Figure 3 also shows the 90% target and illustrates that there is a considerable way to go if New Zealand is to meet the target. There will need to be a significant increase in renewable electricity generation to meet the target covering both new demand and any retired fossil fuel generation.

Total electricity generation in 2011 was 43,100 GWh,<sup>19</sup> of which 33,100 GWh (76.7%) was renewable electricity from hydro, geothermal and wind with very small contributions from wood and biogas. The amount of renewables required in 2025 to meet the 90% target depends on the growth in generation to meet increased electricity demand. An assumed growth rate of 1.6% per annum based on historical rates results in total electricity generation of 53,900 GWh in 2025 while a low growth scenario of 1% per annum results in total electricity generation of 49,600 GWh in 2025. The 90% renewables target is equivalent to total annual renewable generation in 2025 of 48,500 GWh under the high growth scenario and 44,600 GWh under the low growth scenario, representing additional renewables generation of 15,400 GWh/yr and 11,500 GWh/yr respectively.

An increase across all renewable sources of electricity generation, and in particular hydro, wind and geothermal, is needed to meet the target. Other technologies may make contributions in the future, but are currently too expensive. The new installed capacity to achieve the required annual electricity generation to meet the target depends on the actual mixture of technologies. This is because different types of technologies have different capacity factors.<sup>20</sup> The typical capacity factors are around 40% for wind, 50% for hydro and more than 90% for geothermal. The additional renewables capacity required to meet the target would range from around 5,000 MW to 3,000 MW of wind energy under the high and low growth scenarios respectively if comprised entirely of wind; to 4,000 MW and 3,000 MW respectively if comprised entirely of hydro; and 2,200 MW and 1,700 MW respectively if comprised entirely of geothermal. In reality, a mixture of technologies is expected and the total new capacity will be somewhere in the middle of these ranges. For reference, an installed capacity of 4,000 MW is equivalent to approximately 26 wind farms the size of Wellington's West Wind project, or five hydro schemes the size of Manapouri.

The electricity generation capacity required to meet the target will be influenced by a range of factors and ultimately it will be dependent on commercial decisions made by generation developers. Currently, the majority of generation consented but not yet constructed is renewable. This constitutes a supply of projects that can meet future demand, without unnecessary delays and uncertainty.

<sup>19</sup> Ministry of Economic Development (2012) *New Zealand Energy Data File 2011 Calendar Year*, p108.

<sup>20</sup> The capacity factor is the ratio of actual generation output over a year compared to what the plant would have theoretically generated if it had operated continuously at full rated capacity for that year. Capacity factors vary significantly between technologies, with geothermal tending to be quite high and wind somewhat lower (though wind capacity factors in New Zealand are significantly higher than much of the rest of the world). Capacity factors also vary within a technology (e.g. from one hydro dam to another) and capacity factors will vary year to year even for a particular hydro project, pending climatic conditions.

## 3. Renewable electricity generation technologies

New Zealand has significant existing renewable electricity generation and many opportunities for more electricity generation from renewable resources, which can be summarised as:

- hydro
- geothermal
- wind
- biomass
- solar
- marine (wave, tidal, and ocean currents)

Renewable electricity generation exists in New Zealand in a wide range of sizes from very small scale (often referred to as micro-generation) to large-scale generation. Generation can be connected directly to the electricity user, to a local lines company's distribution network, or to the national grid.

The renewable energy potential in New Zealand is extensive. It is described in sources such as EECA's regional renewable energy assessments and the NIWA EnergyScape™ maps. These sources provide information at a general level only. EECA's assessments provide a first order indication of the magnitude and location of the resources based on publicly available information and data. More detailed studies are likely to reveal additional resources suitable for development. Assessments of the magnitude and location of any realisable renewable energy resource may change over time as technology advances.

Further detail of each type of renewable electricity generation is given in the sections below.

### 3.1. Hydro

---

#### Overview

---

New Zealand's geography is well suited to hydro-electricity generation. Hydro-electricity utilises New Zealand's world-class water resources: high rainfall, snow melt and rivers. It has been the backbone of New Zealand's electricity supply system for decades, and hydro dams are a well-known feature of the New Zealand landscape. Hydro-electricity generation facilities currently supply approximately 60% of New Zealand's electricity depending on rainfall. New Zealand has five main hydro-electricity systems, most of which comprise a number of stations located on a river. The systems are: Waitaki, Waikato, Manapouri, Clutha and Tongariro.

Hydro-electricity systems with storage are a flexible form of renewable energy, and in some schemes water may be stored and used weeks later (rather than needing to be consumed immediately). Because of the ability of hydro generation to quickly increase or decrease generation (called ramping up or ramping down) to match demand, storage-hydro plays a key role in New Zealand's electricity system. It also plays a role in frequency keeping,<sup>21</sup> and is well suited to provide electricity that can be dispatched quickly in the case of system disruptions caused by the connection of large loads, the sudden disconnection of another generator or a major distribution disruption.

<sup>21</sup> Electricity generation must be continuously matched to demand on a moment-to-moment basis to ensure that the entire electricity system is maintained in a stable and secure state. For example, even a small increase in demand, without a corresponding increase in supply, will cause the system frequency to fall as rotating generators give up stored energy and slow down. Frequency keeping involves the use of generators able to correct relatively normal changes in frequency.

## How it works

Hydro generation uses the pressure and flow of water to spin a turbine that drives a generator to make electricity. Water is typically impounded by means of a dam, and when released, flows through an intake structure into a canal or tunnel, then into a dedicated pipe (a 'penstock'), and turns a turbine (or 'runner') that drives a generator that generates electricity.

Figure 4 shows the key components of a hydro-electricity scheme and Figure 5 shows the powerhouse at the 800 MW Manapouri hydro-electricity power station.

*Figure 4 Components of a hydro-electricity scheme*

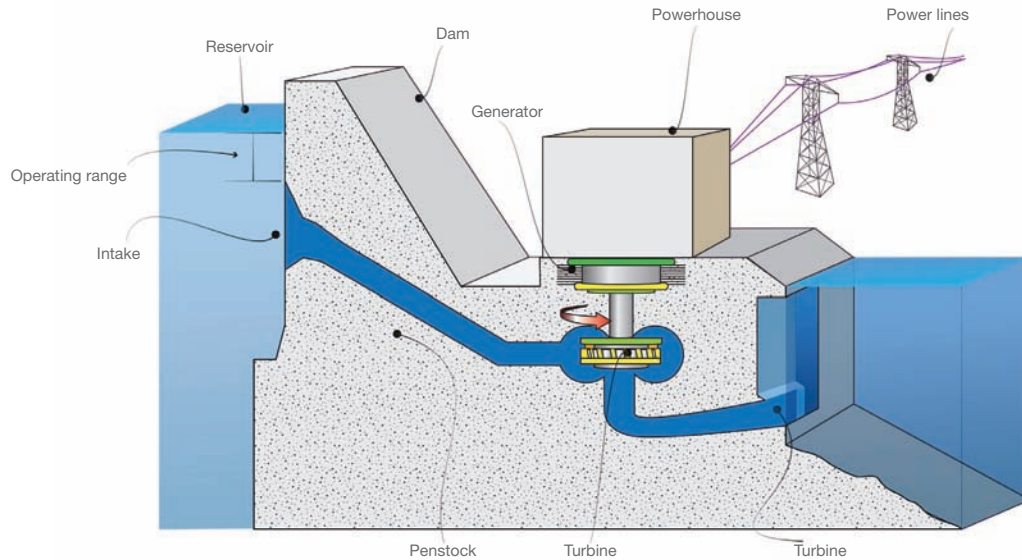

*(Source: EECA)*

The amount of energy available through a hydro-electricity scheme primarily depends on two factors:

1. the height of the water above the turbine (the head)
2. the amount of water passing through the turbine (the flow rate)

*Figure 5 Manapouri hydro-electricity power station Southland*



*(Photo courtesy of Meridian Energy)*



## Different types of hydro technology and their uses

---

Hydro-electricity schemes span all scales from farm-scale (measured in kilowatts) to large multi-megawatt schemes. Typically, schemes can be described by the water flow, being either run-of-river, meaning the hydro scheme generates electricity when water is available with little or no storage and so a close to normal water flow is maintained, or storage schemes that store water to be used when electricity is required. A third alternative is out-of-river, where water is taken from one watercourse and returned to another watercourse via a series of pipes. Run-of-river schemes may be dammed to force water to take a particular path or, alternatively, a fast-flowing natural path may already be formed by a river. While these are the most common interpretations of the terminology, there is some discrepancy in different terminologies used in the industry. In particular, run-of-river is sometimes used to describe schemes that stay within their natural course, not diverting to other waterways.

## Key characteristics

---

### Flexibility and managing storage and inflows

The main hydro-electricity generating catchments in New Zealand are the Waiau (i.e. Manapouri), Clutha, Waitaki and Taupō (i.e. Waikato and Tongariro schemes); only the Taupō catchment is in the North Island. In New Zealand the role of hydro-electricity (and, therefore, to some extent New Zealand's electricity system as a whole) is defined by the fact that the largest inflows into the Clutha and Waitaki storage lakes occur in spring and summer and, to the extent practicable, are stored at that time for later use in winter when demand is high and inflows less. However, for the hydro-electricity on the Waikato River, the largest inflows are usually in winter and spring.

### Long-term storage

In New Zealand, some schemes have the ability to store water for longer periods and therefore provide a significant contribution to meeting longer-term seasonal electricity demand. Such schemes include the storage provided by Lakes Taupō (connected to the Waikato River hydro-electricity scheme), Pukaki, Tekapo (connected to the Waitaki River hydro-electricity scheme), and Hawea (connected to the Clutha River hydro-electricity scheme).

Lake Pukaki has the greatest active hydro storage (i.e. that between the maximum and minimum lake control levels) in New Zealand, with the potential to generate around 1900 GWh of electricity. It is followed by Tekapo with 1,100 GWh of potential electricity generation; Lake Taupō which holds around 600 GWh of potential electricity; and Hawea which is smaller again (around 330 GWh storage). Hawea catches a smaller proportion of inflows than either the Waitaki or the Waikato so the Clutha scheme operates more on a run-of-river basis than they do.

### Short-term storage

The second category is those that have limited storage – perhaps for a few days – and contribute to meeting daily peak demand. For instance, the Clutha River system has long-term storage capacity in Lake Hawea and the ability to store water intra-day (over the period of one day or less) in Lakes Dunstan and Roxburgh.

## Dry year management

New Zealand has comparatively little long-term storage hydro. This means that the amount of generation available month-to-month is highly dependent on rainfall in key catchment areas. Hydro storage therefore needs careful management in maintaining security of supply. During a dry period, dam levels may be low and the available water may be required to preserve the aquatic ecosystems. Additionally, in winter, when power consumption is often greatest, some of the water is locked away as snow in the Southern Alps, and cannot be used until the spring thaw. This problem is addressed in part through using New Zealand's diverse mix of energy sources: for example, using geothermal electricity generation, which is very consistent, and wind energy where available. Other hydro schemes in different regions, if not experiencing low inflows at the same time, may also be used. Climatic differences in the North and South Islands often mean that this can occur and therefore the national average storage position is improved but equally when dry periods in the North and South Islands coincide, a dry hydrological year results, necessitating electricity supply from other sources.

## Hydro operational and maintenance considerations

---

The following are key operational and maintenance considerations for hydro schemes:

- dam safety and the potential impacts of dams on downstream people and property
- for larger schemes, intensive monitoring of climatic and environmental conditions occurs over wide areas
- maintaining water flows and lake levels, as required by resource consent conditions
- keeping the intake clear of debris
- de-silting may need to be addressed over time depending on its effects and rate of accumulation. This can occur in a number of ways, from dredging small reservoirs to altering the sediment transport dynamics in larger reservoirs. It may involve draining a silt trap and excavating silt for smaller dams and diversion structures
- maintaining generating equipment and infrastructure.

Additional information on the benefits and the practical constraints of Hydro-electricity are discussed later in this document.

## Further information on hydro energy

---

### **EECA**

[www.eeca.govt.nz/efficient-and-renewable-energy/renewable-energy/hydro-energy](http://www.eeca.govt.nz/efficient-and-renewable-energy/renewable-energy/hydro-energy)

**Sustainable Electricity Association of New Zealand (SEANZ)** – micro hydro systems

[www.seanz.org.nz](http://www.seanz.org.nz)

## 3.2. Geothermal

---

### Overview

---

Geothermal energy is a significant contributor to New Zealand's electricity supply. It can be utilised to deliver energy 24 hours a day year-round (providing baseload electricity generation and/or heating and cooling requirements). New Zealand's high temperature resources used for electricity generation are found in the Taupō Volcanic Zone and Ngāwhā in Northland, which is the only geothermal resource supporting electricity generation outside the Taupō Volcanic Zone. These are world class resources due to their temperature and permeability at accessible depths.

Figure 6 is a photo of the 138 MW Nga Awa Pura geothermal power station which is one of New Zealand's most recently commissioned stations. It is located on the Rotokawa geothermal field, 14 km north-east of Taupō.

*Figure 6 Nga Awa Pura geothermal power station, Taupō*



*(Photo courtesy of Mighty River Power)*

### How it works

---

Hot water and steam from geothermal systems can be extracted by drilling into the reservoir (geothermal wells). At the surface, the usual practice is to separate the steam and brine (geothermal water with very high concentration of salts) discharging from wells. The fluid is piped above ground to a power station where either steam is used directly in a steam turbine, or the two phase fluid (steam and brine combined) can be passed through a heat exchanger so a secondary fluid can be vapourised and run through a turbine (binary plant).

Excess fluids that remain after the generation process are generally re-injected into the subsurface reservoir, otherwise the fluid, which can contain heavy metals and other contaminants, requires careful management. Re-injection assists in maintaining subsurface pressures and providing fluid that can be reheated by the hot rock for further extraction. Depending on the characteristics of the system, this can help extend the life of the system.

## Different types of geothermal technology and their uses

High temperature geothermal resources can be used for electricity generation. This is usually based on either steam turbine plant or binary plant technology. The different technologies include:

- A back pressure steam turbine (e.g. at the Kawerau mill) where steam passes through a back pressure turbine before being used for mill process steam supplies. Figure 7 illustrates a single flash steam turbine power station. It shows that the two phase fluid (i.e. liquid and vapour) from the production well is separated (flashed). The steam is then used to drive the turbine and the brine is injected back into the reservoir
- A condensing steam turbine (e.g. at Ohaaki or Nga Awa Purua geothermal power stations) where a vacuum is created at the back end of the turbine by a condenser, and for which the cooling water for the condenser is sourced from the condensed steam itself recirculated through cooling towers
- A binary cycle plant (e.g. at Ngāwhā or Te Huka geothermal power stations) where heat from the geothermal fluids is exchanged with a secondary working fluid such as pentane which flashes to a gas and is then passed through a gas turbine before recirculation. Figure 8 illustrates a binary power station. It shows that the two phase fluid from the production well is passed through a heat exchanger, which heats a secondary fluid (e.g pentane) that is used to drive the turbine and the cooled brine is injected back into the reservoir
- A hybrid system, also called a geothermal combined cycle plant (e.g. Mokai or Rotokawa geothermal power stations) which uses a combination of a back pressure steam turbine exhausting at just over atmospheric pressure to a heat exchanger for a binary cycle plant that acts as the steam condenser, with other binary cycle plant for the brine. Figure 9 (refer to page 22) shows an aerial view of the Rotokawa geothermal power station located 14 north-east of Taupō.

Figure 7 Single flash steam geothermal power station

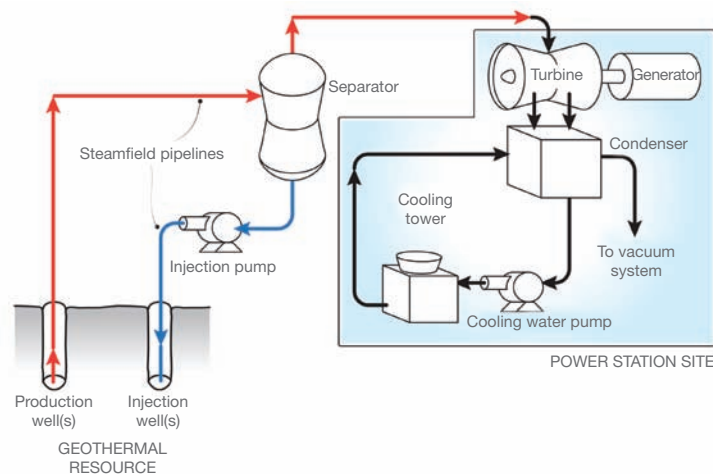

(Source: EECA, adapted from diagram courtesy of Mighty River Power)

Figure 8 Binary geothermal power station

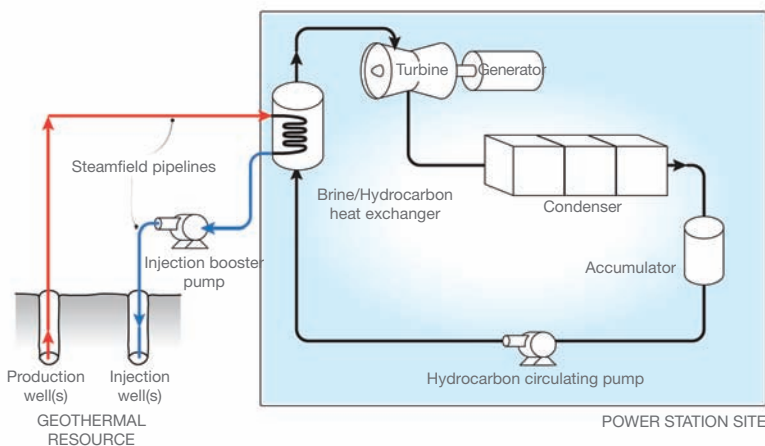

(Source: EECA, adapted from diagram courtesy of Mighty River Power)

Figure 9 Rotokawa geothermal power station, Taupō



(Photo courtesy of GNS Science)

## Cascading uses

When generating electricity from high temperature geothermal resources, surplus heat may be used for primary production and industrial direct heat uses, and/or binary fluid co-generation (known as cascading uses). It is also possible to have various uses in a cascade arrangement progressively extracting more heat. The Huka Prawn Farm, which serves as an aquaculture, tourism and restaurant facility, uses spent geothermal heat from the neighbouring Wairakei Geothermal Power Station to commercially breed and grow tropical giant Malaysian river prawns in captivity.

Figure 10 shows the Wairakei Terraces where silica-enriched geothermal fluid from the Wairakei geothermal power station is piped to the terraces to create an artificial geyser, with the fluid then cascading over the terraces, creating blues and corals. The silica terraces are a tourist attraction for the area.

Figure 10 Wairakei Terraces, Taupō



(Photo courtesy of Contact Energy)

An example of an industrial cascading use is the Ohaaki thermal kilns that take separated geothermal water from the Ohaaki steamfield (i.e. the geothermal water left after Contact Energy has separated out the steam component and piped it to the Ohaaki geothermal power station) and uses the heat from it in two large kilns to dry timber from local sawmills at a site on the western half of the Ohaaki geothermal system.

## Key characteristics

---

### Managing extraction and its effects

Geothermal extraction at a rate sufficient to generate electricity reduces rock temperature and energy stored in the resource faster than it can be naturally replenished, so techniques are employed to ensure that the resource is used sustainably over as long a period of time as possible both in the interests of the geothermal reservoir and the economic return on a power plant. Geothermal extraction can affect geothermal surface features in varying ways: some may increase while others may decline. Therefore planning policy frameworks usually allow electricity generation in some geothermal fields (where there are few surface features or effects, or features can be more readily managed) and not in others. This is to protect geothermal surface features (such as flowing geysers, which are of high value and generally susceptible to subsurface pressure changes resulting from development).

Every geothermal resource responds to extraction and development in a different way, which is reflected in changes in subsurface fluid chemistry, pressures and temperatures, and which can result in effects on geothermal surface features, or geothermal vegetation or ground level. This variability requires sound understanding and active management of the whole field. Certain areas of a geothermal field will be identified by a developer for production while other areas will be identified for re-injection of fluids. Some flexibility needs to be built into the development strategy so that an adaptive management approach can be taken to geothermal system management to respond to changing conditions associated with the reservoir over time. Eventually a field may be rested, after which recovery of pressures and eventually temperatures will be a function of the total fluid withdrawn and the natural rate at which reheating of the fluid recharge into the reservoir occurs.

### Managing discharges

The geothermal steam/water usually contains naturally occurring minerals and dissolved gasses. The water will often have high concentrations of salts (brine) and will contain silica and other natural trace elements such as arsenic, boron and mercury which must be suitably managed. The preferred approach is to inject the fluid back into the ground, either within the reservoir or outside it, at selected locations and depths. In some cases it may be acceptable to dispose at the surface with a sustainable fluid collection and disposal strategy. The gasses created from the extraction of energy from the fluid or steam include carbon dioxide and traces of methane (generally, but not always, less than would be found in fossil fuel power stations). Hydrogen sulphide is also emitted and this can have an odour at some concentrations. The significance of hydrogen sulphide discharges depends on the character of the area, as hydrogen sulphide is often discharged naturally in geothermal areas. Dispersion modelling is generally undertaken at time of design, to assess the potential extent and impact of discharges to air.

## Geothermal operational and maintenance considerations

---

Ongoing maintenance requirements for geothermal electricity generation facilities commonly include:

- monitoring and management of reservoir conditions with a view to maintaining long term operation of the plant. This involves monitoring well temperatures, pressures and chemistry to understand the deep reservoir and to detect reservoir changes, and monitoring flows to better understand the cause of changes and to assess the effects of changed strategy to assess any resource depletion rates. A numerical reservoir model will be developed and refined to assist long-term modelling of operational scenarios and their effects
- monitoring and management (through avoiding, remedying or mitigating) of sensitive environmental issues such as air quality, noise, ground water quality and availability, subsidence, and sensitive vegetation and surface feature changes
- regular inspection and maintenance of surface equipment including the power station, pumps, pipes and vessels, to ensure longevity and to comply with regulations
- regular inspection and maintenance of subsurface wells to manage potential blockages from mineral scaling or corrosion
- monitoring of land surface changes against modelled rates of land subsidence to identify any unpredicted effects on land surface activities
- the development of new wells through the life of a development to compensate for changing conditions in the reservoir and to take account of changing production and re-injection strategies over time
- coordination between competing developers on a field (if more than one) to ensure operations and their effects are within the bounds of the overall field management plan
- consideration of cultural, historical, and economic values associated with significant geothermal features. System management decisions should factor in those values.

Additional information on the benefits and the practical constraints of geothermal electricity are discussed later in this document.

## Further information on geothermal energy

---

### **EECA**

[www.eeca.govt.nz/efficient-and-renewable-energy/renewable-energy/geothermal-energy](http://www.eeca.govt.nz/efficient-and-renewable-energy/renewable-energy/geothermal-energy)

### **The New Zealand Geothermal Association (NZGA)**

[www.nzgeothermal.org.nz](http://www.nzgeothermal.org.nz)

### **GNS Science**

[www.gns.cri.nz/geothermal](http://www.gns.cri.nz/geothermal)

### Overview

By international standards New Zealand has an outstanding onshore wind resource in terms of both quality and extent. New Zealand's long coastline and elevated inland topography provide consistent and relatively strong winds during most of the year. Wind speeds vary around the country but there is significant potential resource at around 8 to 10 metres per second annual average wind speed which is currently within the range of wind speeds required for economic wind farms.

On a regional basis there is a clear concentration of very high-quality wind resource in the lower North Island (Hawkes Bay, Manawatu and Wellington) and Canterbury, Otago and Southland. However, other regions such as from coastal Waikato northwards have a very good wind resource as well. It is estimated that wind energy generation could fulfil 20% of New Zealand's electricity demand<sup>22</sup>, a substantial increase on the current generation which was 4.5% in 2011.

Wind farms in New Zealand vary in size, both in the number of turbines and the size and generation capacity of turbines.<sup>23</sup> At the larger scale, Project West Wind in Wellington has a capacity of 142 MW and consists of 62 turbines each with a capacity of 2.3 MW. The turbines stand just over 100 metres tall: the towers are 67 metres; and the blades are 40 metres. The wind farm generates as much electricity as 70,000 homes would use which is the equivalent of all the homes in Wellington City. Smaller wind farms utilise turbines less than 1 MW. The Mt Stuart wind farm in Otago utilises nine wind turbines, each with a capacity of 850 kW. Turbine towers are 45 metres tall with a blade length of 26 metres.

### How it works

Producing electricity from wind generation uses moving air to turn the rotor of the wind turbine that in turn is connected to an electricity generator. Figure 11 illustrates the main components of a wind turbine.

The amount of energy generated by a turbine depends on the size of the turbine, the average wind speed and the consistency of the wind.

Wind speeds increase with distance above ground level. In addition, power output rises with rotor diameter. Increases in tower height expose the rotor to faster and less turbulent wind and also allow for proportionally larger rotors. These factors combine to increase the amount of wind energy harnessed.

A wind farm is comprised of one or more wind turbine generators (wind turbines). The infrastructure associated with a wind energy facility will usually comprise an electrical substation and control building, electrical cabling between turbines, a construction compound (temporary), road access and on-site tracks and flat areas near each turbine for the crane. Most wind farms will include one or more wind monitoring masts to measure the wind speed at the wind turbine height.

Figure 11 Components of a wind turbine

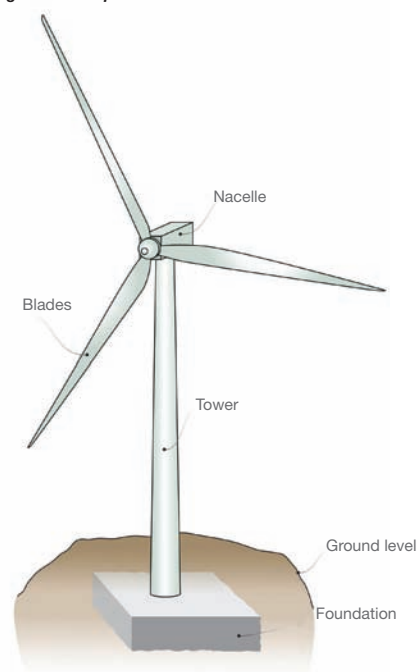

(Source: EECA)

22 New Zealand Wind Energy Association (2012) *Wind Energy 2030: The growing role for wind energy in New Zealand's electricity system*.

23 Information on wind farms operating in New Zealand is available online at [www.windenergy.org.nz/nz-wind-farms/operating-wind-farms](http://www.windenergy.org.nz/nz-wind-farms/operating-wind-farms)



## Different types of wind technology and their uses

---

Three-blade, up-wind rotor horizontal axis wind turbines are the industry standard and are used in almost all commercial wind farms across the world. The majority of New Zealand wind farms utilise three-bladed turbines (see Figure 12 and Figure 13 for examples). There is also a smaller two-bladed turbine operating in New Zealand (Te Rere Hau wind farm).

Figure 12 Tararua wind farm, Manawatu



(Photo courtesy of TrustPower)

Figure 13 Hau Nui wind farm, Wairarapa



(Photo courtesy of Genesis Energy)

As the wind passes through the turbine the wind is decelerated, converting the wind's kinetic energy into rotational energy to drive the generator. Wind turbines must be spaced apart, particularly along the predominant downwind direction. This is to ensure that down wind turbines can have clear air (both in terms of wind speed and turbulence).

## Key characteristics

---

Wind farm electricity output is variable in the short term – minutes and hours; however, over longer time scales – seasons and years – wind is a very reliable natural resource, and is significantly less variable than hydro on this timeframe.

While short-term variability cannot be controlled, any impacts can be offset by having a diverse range of flexible generation sources to support wind generation. New Zealand is fortunate because it has a large proportion of hydro-electricity generation with storage which is controllable and can be used to provide generation flexibly to respond quickly to wind energy variability without incurring large operating costs. In addition, wind generation functions as a complementary component of the electricity generation system, allowing hydro inflows to be stored for later use during periods of low wind generation output.

The net effect of short-term wind variability is also reduced by the development of geographically diverse renewable generation. It is expected that improved wind forecasting will assist the integration of larger amounts of wind generation in future.

## Wind farm operational and maintenance considerations

---

Examples of the common ongoing requirements for wind generation facilities include:

- undertaking planned maintenance of individual wind turbines, typically every six months for each turbine. In a large wind farm this means that a small maintenance team is continually moving around the wind farm completing the routine maintenance
- undertaking unplanned maintenance of wind turbines when faults or defects occur, which may vary from minor issues requiring a few hours of work such as replacing cooling fluids, through to replacement of major components such as a blade, gearbox or rotor which may require lifting the nacelle of the turbine down to the ground
- undertaking planned and unplanned maintenance on the site infrastructure such as roads (e.g. resurfacing, repairing erosion damage from heavy rains) and electrical cabling (e.g. repairing cable faults or faulty cable joints)
- investigating opportunities to improve output of the wind farm such as retrofitting of turbine components suggested by the turbine manufacturer.

## Upgrading

Upgrading is the improvement of an existing component of the wind farm infrastructure and can be modifying new technology to increase the efficiency of the plant or repowering the wind farm.

## Repowering

Wind turbines have a finite life – typically about 25 years. However, because the wind resource is renewable, the site itself is likely to have ongoing value as a wind farm. Therefore, it is possible that the site could be re-used. This is often termed ‘repowering’. It involves replacing turbines that have reached the end of their useful life with the latest turbine technology in order to continue to make the best use of the available wind resources.

Additional information on the benefits and the practical constraints of wind energy are discussed later in this document.

## Further information on wind energy

---

### EECA

[www.eeca.govt.nz/efficient-and-renewable-energy/renewable-energy/wind-energy-in-nz](http://www.eeca.govt.nz/efficient-and-renewable-energy/renewable-energy/wind-energy-in-nz)

### The New Zealand Wind Energy Association (NZWEA)

[www.windenergy.org.nz](http://www.windenergy.org.nz)

### NIWA

[www.niwa.co.nz/news-and-publications/publications/all/wa/13-4/wind](http://www.niwa.co.nz/news-and-publications/publications/all/wa/13-4/wind)

## 3.4. Biomass

---

### Overview

---

Biomass is a form of bioenergy that refers to organic materials used as renewable energy sources such as wood, crops and organic waste (e.g. paper, wood residues, crop harvest waste). Bioenergy can be converted and used to generate electricity, heat or transport fuels. Much waste biomass is available through household rubbish, forestry, agriculture and other industries dealing in organic matter. New Zealand has significant biomass potential but utilising biomass for electricity generation on a stand-alone basis can be costly due to fuel collection, transport and processing requirements. A more common use in New Zealand is in co-generation plants that use wood residues from an industrial site (e.g. saw mill) to fire a boiler where the steam can be used to generate electricity and also provide process heat to the plant (e.g. for kiln drying wood).

### How it works

---

Biomass may be used in solid form or converted to liquid (biofuel) or gas (biogas) for use in electricity generation. Solid biomass (such as wood chips – see Figure 14) can be burnt and the heat can be used directly in industrial plant, or used to heat water and generate steam to drive a turbine to produce electricity (or both).

Burning biomass releases carbon dioxide when combusted, but is similar to the natural carbon cycle (compared with fossil fuels, which have been removed from the carbon cycle for millennia) because carbon dioxide is absorbed by plants as they grow.

Figure 14 Biomass feedstock (wood chips)



(Photo courtesy of the Dunedin Energy Cluster)

Gasification is the partial combustion of solid fuels such as biomass. This yields carbon monoxide and hydrogen which can either be combusted as a clean burning fuel in a gas engine to generate electricity or be further reacted to form liquid biofuels equivalent to normal petrol or diesel.

However, these biofuels such as biodiesel and bioethanol are more commonly used for transport where they have much higher value, rather than electricity generation where there are many alternative fuels.

Biogas is produced by decomposition of organic material in oxygen-starved conditions (such as landfills and at waste treatment plants) and may be burnt directly or in a gas engine to produce electricity.

## Different types of biomass technology and their uses

---

Due to the specialised nature of the combustion furnaces and pressurised boiler systems required to generate electricity (as opposed to just direct heat), electricity generation opportunities are generally found with food or forestry processing plants, where biomass waste is available.

It is generally possible to co-fire or replace coal with biomass. This can present an opportunity to make use of waste organic matter and reduce the amount of coal burned.

Beyond burning plant matter, many other opportunities exist to harness biomass by-products, including biodiesel, waste water treatment plants, solid waste, hydrogen and landfill gas, all of which may be used to generate electricity or burned for direct heat.

Air emissions control technologies may be required to capture fine particulate emissions (e.g. fine particulate matter (PM<sub>10</sub>)). These can include bag filters, cyclones and electrostatic precipitators.

## Key characteristics

---

Bioenergy is a flexible stored energy form and so can complement other renewable energy sources such as wind, hydro, photovoltaics (solar cells for electricity) and geothermal energy. Biomass electricity generation plants are relatively expensive to build but have comparatively low fuel cost if utilising low-value waste available locally. They are very location specific as transport and storage of fuel can be expensive.

The ash produced in biomass combustion is not toxic, unlike that produced by coal combustion. The ash can be used on soil.

## Operation and maintenance considerations for biomass electricity generation

---

Examples of the common ongoing requirements for biomass facilities include:

- undertaking planned maintenance of boiler plant, steam turbine, cooling system, fuel handling system and related infrastructure in a combustion biomass plant. The equipment used is similar to that of conventional coal-fired power generation plant so skills are transferable
- undertaking unplanned maintenance when faults or defects occur. Biomass plants tend to be single power generation trains (one boiler and one steam turbine) so failure or planned maintenance on a key component can require complete shutdown of the plant
- fuel handling in biomass facilities can be challenging as blockages can occur in the transportation systems that deliver the processed fuel to the boiler. Light-weight fuels are often transported to the boiler in air-blown ducts while heavier fuels may use conveyor belts
- operation and maintenance of bioenergy facilities using gasification processes are more complex and requires specialist skills
- operation and maintenance of gas engine equipment used to generate electricity from waste gases such as landfill gas are relatively straightforward and low cost
- monitoring of odours and emissions to air are the main environmental considerations from biomass operations.

Additional information on the benefits and the practical constraints of biomass energy are discussed later in this document.

## Further information on biomass energy

---

### EECA

[www.eeca.govt.nz/efficient-and-renewable-energy/renewable-energy/bioenergy](http://www.eeca.govt.nz/efficient-and-renewable-energy/renewable-energy/bioenergy)

### Bioenergy Association of New Zealand (BANZ)

[www.bioenergy.org.nz](http://www.bioenergy.org.nz)

## 3.5. Solar

---

### Overview

---

Solar energy is the radiant energy of the sun that can be converted into other forms of energy, such as heat or electricity, and is the most abundant renewable energy source available. New Zealand has a good solar resource with solar radiation levels equivalent to southern France in many locations. Currently in New Zealand, solar electricity is used mainly in residential domestic-scale applications and a few individual industrial applications. It is not yet used for commercial-scale electricity generation because it is generally more expensive than grid electricity (which also has a high proportion of renewable generation).

### How it works

---

There are two main ways in which solar energy is converted to electricity. It can be converted directly via photovoltaic (PV) panels, and indirectly whereby solar energy is concentrated to create heat which is used to generate steam which is passed through a steam turbine – referred to as solar thermal-electric technology. Both technology types are decreasing in cost over time as the technology matures and manufacturing processes improve.

### Different types of solar technology and their uses

---

PV modules (or panels) are generally either mounted on roofs or on the top of purpose-built frames in an 'array' for maximum sun exposure. Each module contains a number of electrically-connected solar cells. These solar cells contain a semi-conductor material, usually silicon.

Light contains particles called photons, and when light hits the solar cells photons are absorbed, freeing electrons in the silicon crystal. This allows them to flow through the cell layers to electrical wiring creating an electrical current. A single panel consists of many cells placed adjacent to one another.

PV systems range in size from large-scale power stations to building rooftops and small stand-alone devices. Rooftop applications typically use a fixed mounting arrangement (see Figure 15).

Figure 15 Roof-mounted PV array

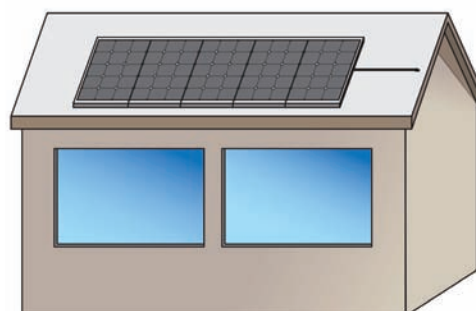

(Source: EECA)

Large arrays often use single-axis or two-axis tracking to follow the sun throughout the day and adjust for seasonal changes to maximise energy capture. Figure 16 shows a 360-panel (62 kW) ground-mounted array in South Auckland.

Figure 16 Ground-mounted PV array, Drury, Auckland



(Photo courtesy of SAFE Engineering and What Power Crisis)

## Key characteristics

---

PV panels are a variable generation source and do not generate electricity at night. Less energy is generated in cloudy weather.

Grid-connected systems require a grid-connected inverter. Surplus electricity generated can then be injected into the local network.

For remote area power systems (RAPS) with no grid connection the components in addition to the panels are an inverter/charge controller, and battery bank, and backup generation (e.g. a small petrol-powered generator that can be run when required to charge the batteries).

While photovoltaics are often used in remote areas where connection to the electricity network is difficult or expensive, they are also appearing in urban environments where they are connected to the distribution network or national grid (even though they are generally more expensive than grid electricity).

## Solar array operational and maintenance requirements

---

PV solar facilities have no moving parts, and therefore require minimal maintenance.

Solar arrays lose some efficiency over their life due to degradation of the cell materials. Different types of PV panels have different degradation curves; however, on average efficiency declines at a rate of about 5% per decade, and manufacturers typically guarantee output to be at least 80% of the original rating after 25 years.

Additional information on the benefits and the practical constraints of solar energy are discussed later in this document.

## Further information on solar energy

---

### EECA

[www.eeca.govt.nz/efficient-and-renewable-energy/renewable-energy/solar-energy-in-nz](http://www.eeca.govt.nz/efficient-and-renewable-energy/renewable-energy/solar-energy-in-nz)

### SEANZ

[www.seanz.org.nz](http://www.seanz.org.nz)

### EECA publication “Power From the People: A Guide to Micro-generation”

[www.eeca.govt.nz](http://www.eeca.govt.nz)

### Overview

---

Electricity generation using marine energy is a technology that is developing globally and in New Zealand. Currently there are no commercial-scale marine energy electricity generation plants in New Zealand. However, New Zealand has significant marine energy resources, particularly wave energy, which may contribute to future electricity supply if technologies mature and costs reduce below those of competing renewable options.<sup>24</sup>

### How it works

---

Marine energy involves using the potential, heat and chemical properties of seawater to generate electricity. Marine resources for electricity generation can be divided into wave, tidal range, tidal and ocean currents, ocean thermal and salinity gradient.

There is a wide range of options for extracting energy from marine resources although there is no common design, as there is for wind turbine generators. This reflects the current immaturity of the technology.

*Figure 17 Prototype marine energy device, Wellington Harbour*



*(Photo courtesy of WET-NZ)*

Tidal energy can be split into two basic forms:

- Tidal rise and fall is controlled by the relative position and gravitational attraction of the moon and, to a lesser extent, the sun, on the world's oceans. The tides follow a diurnal cycle (based on 24-hour intervals) slightly longer than a normal day, and a seasonal cycle. Tidal rise and fall is very predictable and easily forecast
- Tidal/ocean currents arise from the diurnal rise and fall, and are also modified by local weather effects and local seabed and land topography. Tidal stream currents are therefore less predictable than the tides because of weather effects.

Wave energy for electricity generation can be separated into two potential sources: open ocean swells and breaking waves.

- Open ocean swells result from the aggregated effects of wind currents blowing across the surface of the ocean, particularly in major storms. Ocean swells result from the constructive interference of waves resolving into larger waves with bigger amplitudes (i.e. wave height) and longer wavelengths (i.e. longer periods between wave peaks). Breaking waves result from the incidence of these ocean swells on the seabed, as waves approach the coast
- Breaking waves occur when two or more swells approach the coast and suffer friction in the shallower water, which causes slower waves with increasing wave heights and the continuing friction causes the waves to eventually topple over, breaking on the beach.

Figure 17 shows a prototype marine energy device tested in New Zealand.

24 Power Projects Limited (2008) *The Development of Marine Energy in New Zealand*, p2. Prepared for the Energy Efficiency and Conservation Authority and the Wellington Regional Council.

## Different types of marine technology and their uses

---

Several types of tidal turbine design exist to harness electricity from tidal rise and fall (these are simply low-head hydro technologies) and from tidal/ocean currents. There are two basic tidal rise and fall technologies:

- Tidal barrages which extend across the narrow mouth of a bay, estuary or river. Barrages disrupt the normal tidal rise and fall, holding back the rising or falling water such that water level on one side of the barrier or impoundment is out of synchronisation with the water level on the other side. As the point of maximum difference is reached, the barrage or impoundment mechanism is opened, allowing flow across it. The flowing water is used to generate electricity and can be utilised on both the ebb and the flood tide
- Tidal stream turbines such as horizontal axis turbines. Although there are significant differences in details, this class of device is conceptually similar to the standard wind turbine generator (i.e. a single monopole tower with an upwind rotor and turbine, connected through a gearbox to a horizontal axis generator).

Ocean current electricity generation facilities operate in a similar fashion to tidal electricity generation as described above, although tidal is more likely to be feasible in the near term due to being closer to grid connection points, and the tidal current velocities being higher (thus more energetic).

There is a very wide variety of proposed wave electricity generation designs, which use different methods to harness the energy contained in the movement of water known as waves.

## Key characteristics

---

With the exception of tidal barrages which involve large structures, marine energy devices are similar to wind farms in that the individual turbine unit is small, but many units are required to make up the overall project. Some marine energy resources (e.g. tidal currents) have a higher energy density than wind so these devices tend to be smaller than wind turbines for similar generation capacity; conversely, wave devices are often similar or larger than wind turbines of the same output.

Tidal energy is relatively predictable which would be beneficial if the energy source makes up a material proportion of the overall generation.

Wave energy is more variable, but like wind, it is able to be usefully forecast.

## Operational and maintenance requirements for marine electricity generation

---

Requirements for marine electricity generation assets vary greatly because of the variety in types and designs of the technology. Operation of any marine electricity generation facilities must provide for the effect of storms, particularly for wave electricity generation. Submarine devices are designed as modular units, but access can be limited by bad weather, and maintenance is a significant cost compared to land-based renewable technologies. The harsh environment for electrical equipment is a further consideration as is build-up of marine flora and fauna.

Additional information on the benefits and the practical constraints of marine energy are discussed later in this document.

## Further information on marine energy

---

### **EECA**

[www.eeca.govt.nz/efficient-and-renewable-energy/renewable-energy/marine-energy](http://www.eeca.govt.nz/efficient-and-renewable-energy/renewable-energy/marine-energy)

### **Aotearoa Wave and Tidal Energy Association (AWATEA)**

[www.awatea.org.nz](http://www.awatea.org.nz)

# National Policy Statement for Renewable Electricity Generation – Technical Information on Policies

*This section of the guide provides an explanation of the technical concepts and terms associated with the National Policy Statement for Renewable Electricity Generation (NPS REG). It is focused on the positive effects of renewable electricity generation (REG) activities and does not provide guidance on adverse environmental effects that can span local, regional and national scales other than in association with the day-to-day operation and maintenance of REG activities.*



## 4. Policy A: Benefits of renewables

### **A. Recognising the benefits of renewable electricity generation activities**

#### **Policy A**

*Decision-makers shall recognise and provide for the national significance of renewable electricity generation activities, including the national, regional and local benefits relevant to renewable electricity generation activities. These benefits include, but are not limited to:*

- a) maintaining or increasing electricity generation capacity while avoiding, reducing or displacing greenhouse gas emissions;*
- b) maintaining or increasing security of electricity supply at local, regional and national levels by diversifying the type and/or location of electricity generation;*
- c) using renewable natural resources rather than finite resources;*
- d) the reversibility of the adverse effects on the environment of some renewable electricity generation technologies;*
- e) avoiding reliance on imported fuels for the purposes of generating electricity.*

Policy A requires a broad understanding of the nature, extent and location of relevant developed and undeveloped renewable resources and the associated national, regional and local benefits. Information on the current renewable energy potential can be derived from sources such as EECA's regional renewable energy assessments, and the NIWA EnergyScape™ maps and from consultation with electricity generators.

The benefits of renewable electricity generation activities can occur on a local, regional and national scale. The following section provides information on the benefits list in Policy A. It also describes other general benefits of electricity generation along with benefits specific to each renewable electricity technology noting this is not an exhaustive list.

#### **Policy A**

##### ***a) Maintaining or increasing electricity generation capacity while avoiding, reducing or displacing greenhouse gas emissions***

One of the principal contributors to climate change is greenhouse gas emissions generated from human activities, such as the burning of fossil fuels for electricity generation. Renewable electricity generation contributes towards meeting electricity demand without emitting greenhouse gases (other than the small amount emitted during construction or during the production of electricity from geothermal resources – referred to as fugitive emissions which occur when CO<sub>2</sub> comes to the surface with the geothermal fluids and is released). Emissions from geothermal vary from field to field but its CO<sub>2</sub>e emissions are currently lower on average than fossil fuel generation.

Internationally, New Zealand has a significant advantage as its electricity has one of the highest renewable proportions globally, and has potential for significantly greater utilisation of renewable electricity. Renewable electricity generation provides a cost effective option for avoiding increased greenhouse gas emissions in the future.

This is important given national and international aspirations to address greenhouse gas emissions. New Zealand's national climate change target is for a 50% reduction in greenhouse gas emissions from 1990 levels by 2050.

In 2010, New Zealand's total greenhouse gas emissions had increased by 19.8% above 1990 levels with CO<sub>2</sub> emissions increasing 32.7%.<sup>25</sup> More gas-fired electricity generation, and increased use of coal at Huntly power station (which can run on either gas or coal), contributed to this. Figure 18 shows the changes in electricity generation by fuel type in New Zealand.<sup>26</sup>

Figure 18 Electricity generation in New Zealand by fuel type

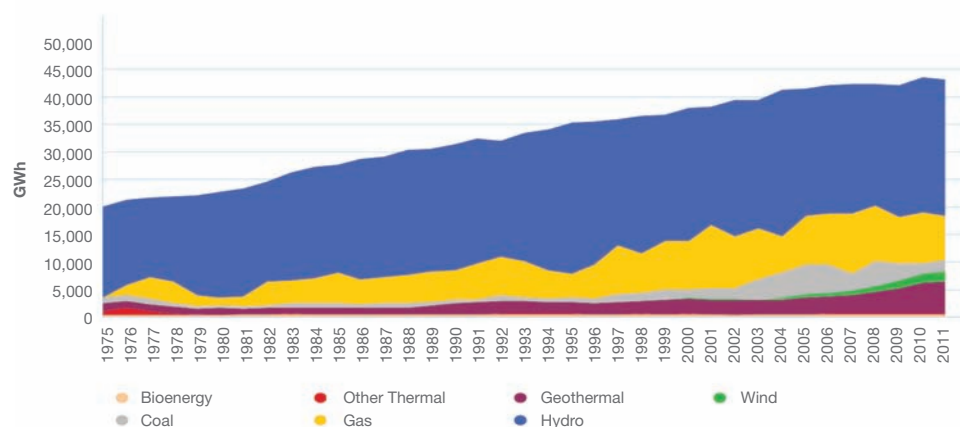

(Source: Energy Data File 2012)

## Policy A

### b) Maintaining or increasing security of electricity supply at local, regional and national levels by diversifying the type and/or location of electricity generation

## Security of supply

Security of electricity supply has several elements to it and is fundamentally the ability of the electricity system to meet the demands of electricity consumers, meeting both current demand (as it varies throughout the day and the year), and meeting growing future demand. Security of supply requires sufficient generation capacity and fuel to meet demand. The nature of electricity means that, once generated, it cannot be stored within the power system for any material time. Electricity must therefore be generated on demand and coordinated on a moment-to-moment basis to maintain supply to consumers.

Renewable electricity generation can improve the security of New Zealand's electricity supply by achieving the following:<sup>27</sup>

- increased generation capacity (i.e. maintaining sufficient levels of generation capacity and fuel to meet existing and future demand)
- diversified type and location of electricity supply (i.e. having a variety of generation capacity and type that contributes to a robust and resilient electricity system)
- long-term availability of a renewable energy supply in comparison with fossil fuel supply which is finite.

## Meeting demand

A secure and reliable electricity supply is essential for New Zealand's economy, and our well-being. Over the long term, New Zealand's electricity demand is forecast to continue to grow and new generation will need to be built in order to meet growing demand for electricity and replace retired generation assets.

25 Ministry for the Environment (2012) *New Zealand's Greenhouse Gas Inventory 1990–2010*, p28, 31.

26 Ministry of Economic Development (2012) *New Zealand Energy Data File 2011 Calendar Year*, p103.

27 Note that these potential benefits are not exclusive to renewables and may also apply to fossil fuel generation.

## Diversification

---

Diversity is another important element of maintaining and improving security of electricity supply. The electricity system will be more resilient to sudden and unexpected changes, such as fuel price shocks or natural disasters, if electricity is obtained from a diverse range of generation sources. Hydro-electricity provides approximately 60% of New Zealand's electricity. While this brings with it great benefits, it also means that the system is very dependent on rainfall to provide inflows into the hydro storage systems for winter's higher electricity demand.

Diversity of electricity sources – for instance, providing generation from wind and geothermal energy as well as hydro-electricity – contributes to system resilience by providing alternative generation to hydro particularly in dry years. Each resource type has different characteristics. Wind generation is very reliable month to month and year to year, complementing more variable hydro renewable energy sources. Geothermal generation operates at higher load factors compared to hydro and wind generation and uses a constant fuel source day-to-day and year-to-year meaning it provides a reliable and constant amount of electricity generation (often referred to as 'baseload generation'). Hydro storage-based generation provides flexible electricity generation. Although not yet widely used, solar can provide excellent supply in urban areas, as sunshine hours coincide with the demand from office and air conditioning loads.

Geographic diversity of the electricity system as a whole is also important and adds to the system's resilience. For example, wind generation spread throughout the country reduces the effect of short-term wind variability in any one location.

### **Policy A**

#### ***c) Using renewable natural resources rather than finite resources***

The utilisation of renewable resources such as hydro, wind, tidal, solar, geothermal and biomass does not deplete finite resources. This means that it could be used sustainably for current and future generations. To ensure that geothermal and biomass remain long-term sources of renewable energy, careful management is required.<sup>28</sup>

Conversely, fossil fuels which are used in thermal generation are finite resources. Although thermal generation typically has a relatively lower 'upfront' capital expenditure, it has higher ongoing fuel costs, and the costs of carbon if applicable.<sup>29</sup>

### **Policy A**

#### ***d) The reversibility of the adverse effects on the environment of some renewable electricity generation technologies***

Reversibility has been defined as whether an adverse effect can be reversed at the end point of a project to a state where offsite adverse effects are no more than minor.<sup>30</sup> Research shows that adverse environmental effects from hydro-electricity, geothermal<sup>31</sup> and wind technologies are all largely reversible. For example, a wind farm can be decommissioned in its entirety with all turbines and other above ground structures being removed and turbine footing covered and re-vegetated.

Reversibility is based on the restoration timeframe, costs of removal and restoration and the level of treatment required. However, there is differing ease in reversing the adverse effects across the different renewable types. For example, adverse effects from wind farms are the most easily reversed, followed by geothermal, then from hydro which takes the longest and is the most expensive to restore.<sup>32</sup> In some cases the cost may outweigh the benefits of restoration.

<sup>28</sup> In the case of geothermal energy there can be controlled depletion of a local resource, but this can be restored over time because of the effectively infinite source of heat below the affected area, assisted by flow of fluid back into the reservoir and deep convection.

<sup>29</sup> Concept Consulting Group (2009). *Renewable Generation and Security of Supply*. Prepared for the Energy Efficiency and Conservation Authority

<sup>30</sup> Oldham, K (2008). *Reversibility of Renewable Energy Developments*.

<sup>31</sup> Some aspects of geothermal development are not fully reversible. Subsidence is not reversible, but the permanent lowering of land is generally of minor impact, unless there is a risk of flooding or there are buildings/infrastructure located at the edge of a significant subsidence bowl. Where surface discharges are depleted or cease, while total discharge will be restored, it is not certain that the original features will recover and new geothermal features may develop. Any ecosystem rendered extinct by the cessation of flow will be replaced by new ecosystems, possibly with reduced biodiversity and resilience.

<sup>32</sup> Ibid, 30.

## Policy A

### e) Avoiding reliance on imported fuels for the purposes of generating electricity

Renewable energy projects utilise a local renewable energy resource, potentially reducing the use of imported fossil fuels for the purposes of generating electricity. (This depends whether gas, coal or other renewables are the likely alternative.) Once constructed, the cost of electricity produced from renewable electricity generation is not affected by international or local fuel prices and so can provide a natural hedge, or insurance, against rising and volatile carbon prices and fossil fuel prices. Fossil fuel generation by comparison has lower 'upfront' capital costs and higher ongoing fuel costs when compared with renewable alternatives. Fossil fuel generation is therefore exposed to changes in the price of fossil fuel over time.

Fossil fuel electricity generation in New Zealand in 2013 relies on both domestic and imported coal, in which case coal prices in New Zealand are to some extent linked to the international market and are subject to global supply and demand. There is currently no import or export of natural gas in New Zealand: the price of gas is primarily determined by domestic supply and demand. While some renewable generation is currently cheaper than gas-fuelled generation, this may change in future if new large gas fields which depress the domestic gas price are developed. However, if a gas export capability (e.g. LNG terminal) is built in New Zealand, it is unlikely gas will be used for electricity generation domestically<sup>33</sup> because the gas will be higher value as an export, and New Zealand has cheaper renewable electricity generation options.

By contrast, these price risks are not generally encountered with renewable technologies as the fuel source is not subject to commodity price volatility. Also, the effective price of all fossil fuels will be influenced by national and international carbon prices because of the need to take account of associated greenhouse gas emissions. New Zealand faces a cost for such emissions and this cost is difficult to predict over time. Production of electricity from renewable resources creates few emissions, reducing New Zealand's net exposure to costs associated with carbon liabilities.

## Other benefits

There is a range of other benefits of renewable electricity generation facilities, including:

- development of specialist green skills and experience that can be exported overseas, such as New Zealand's geothermal skills that are in demand for new geothermal projects around the world
- it is also benign in terms of air quality, with no emission of contaminants into the air, except in the case of geothermal and biomass where there are some emissions
- in general, there is a reduction in transmission and distribution line losses if the facility is closer to a demand load and / or embedded in a local distribution network.

## Benefits specific to electricity generation using hydro resources (with storage)

- Hydro-electricity with storage has the advantage that it is more controllable and can be correlated with demand. Figure 19 shows Lake Pukaki which has the greatest active hydro storage in New Zealand

Figure 19 Lake Pukaki (Waitaki River hydro-electricity scheme)

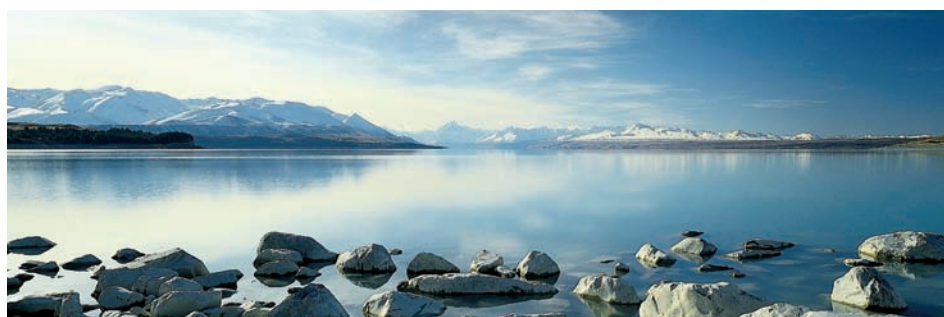

(Photo courtesy of Meridian Energy)

<sup>33</sup> This would depend on domestic gas fields having access to the Liquefied Natural Gas export terminal.

- Hydro storage can be controlled, and is therefore very valuable in an electricity system where demand, and some generation sources (e.g. run-of-river hydro and wind), are varying hour to hour. This means that hydro-electricity is particularly important in maintaining security of supply as it is able to adapt to and complement changing generation and demand patterns and allow New Zealand to maximise its renewable resources at least cost. In the future, with an increasing share of generation being met by wind, this feature will become even more important
- Hydro-electricity provides both instantaneous reserves and frequency keeping
- The creation of lakes contributes to tourism and provides recreational opportunities (e.g. boating and swimming). New Zealand's two main rowing race courses are based on lakes created for hydro-electricity generation
- Hydro scheme infrastructure can provide opportunities for irrigation schemes to access secure supplies of water that would not be economically viable if the hydro-electricity generation facility did not exist and to reduce the costs of operating and maintaining headworks infrastructure through shared use of resources and expertise.

## Benefits specific to electricity generation using geothermal resources

- It provides a good source of non weather-dependent reliable baseload renewable electricity generation (i.e. a consistent source of electricity)
- The continuous nature of the fuel source as constant steam fluid from geothermal reservoirs provides very high power station capacity factors well above 90%. Once a geothermal electricity station is generating it will operate continuously except for planned maintenance cycles and forced outages
- New Zealand's main geothermal resources are located in the North Island in close proximity to the largest electricity demand centres and therefore result in reduced transmission losses in the electricity system, contributing to the efficient end use of electricity
- Generally, the power stations have a small footprint and low height (excluding vapour plumes) and therefore a low visual impact (although associated steam fields can cover several square kilometres). Figure 20 shows the cooling towers at the Ngāwhā geothermal power station in Northland.

*Figure 20 Ngāwhā geothermal power station, Northland*



*(Photo courtesy of Top Energy)*

- Geothermal generation currently represents the lowest cost generation options available in New Zealand from all fuel types including fossil fuel options
- It is possible to use steam condensate for irrigation purposes
- Developments frequently are based on partnerships with Māori so there are flow-on benefits to this sector of society
- Developments draw on the world-leading expertise of New Zealand geothermal consultants and hones their skills for the international market
- There may be opportunities to use surplus heat for primary production and industrial direct heat uses and/or other cascading uses
- Developments are to some degree compatible with other land uses such as farming and forestry (though generally not with direct geothermal tourism as geothermal generation can reduce activity of geothermal surface features; indirect tourism may arise from the generation site itself).

## Benefits specific to electricity generation using wind resources

---

- Electricity generated from wind resources utilises an abundant resource which is yet to be fully utilised
- New wind generation, together with geothermal, will contribute to a more balanced portfolio of renewable generation technologies, reducing the electricity sector's exposure to dry year risk. This is because wind generation is very reliable over the longer term (month to month and year to year); it is much less variable than hydro inflows. In the short term, hydro-electricity generation with storage can be used to provide generation flexibly to respond quickly to wind energy variability without incurring large operating costs
- Wind generation can be usefully forecast. While wind is variable over the short term, it is predictable and less variable than hydro. This makes managing wind variability in the short term easier, as increases and decreases in wind generation can be forecast hours and days ahead with useful accuracy. Short-term wind variability can also be reduced by developing geographically diverse wind farms. Having wind farms in different wind regions means that while one may not be generating, another might be, thus having a smoothing effect on overall national generation from wind
- Wind farm developments can co-exist with other land uses such as agricultural activities creating sustainable, mixed land use. (See Figure 21 showing Project West Wind.)
- Turbines can attract tourism and provide recreational opportunities such as mountain bike tracks or hiking within wind farm locations
- Maintenance of wind farms can be carried out with minimal disruption to electricity generation (unlike some other types of power stations) as a single turbine can be repaired without requiring a whole wind farm to cease generation.

*Figure 21 Project West Wind, Wellington*



*(Photo courtesy of Meridian Energy)*

## Benefits specific to electricity generation using biomass resources

---

- Biomass resources are predictable and manageable – the volume of the available resource can be predicted in advance and managed to meet energy demands
- Biomass can be stored and transported (though at a cost) and used where and when required. Figure 22 shows a large scale biomass storage facility

Figure 22 Biomass feedstock storage



(Source: EECA)

- Biomass can be used efficiently by producing heat and electricity through combined heat and power plants
- Biomass can be converted to biogas for electricity generation.

## Benefits specific to electricity generation using solar resources

---

- Solar energy is an abundantly available and evenly distributed resource and as such can be applied at almost any location in the country
- Solar electricity can (with increased uptake) contribute to a more balanced portfolio of renewable generation technologies, reducing the electricity sector's exposure to dry year<sup>34</sup>
- Solar electricity generation systems can be installed close to (or on) the point of use, reducing transmission losses and contributing to the efficient end use of electricity. Figure 23 shows PV panels mounted on the roof a remote hut

Figure 23 Roof-mounted PV array



(Crown copyright: Department of Conservation: Te Papa Atawhai 2009)

- There are no noise impacts of solar electricity generation
- Solar electricity generation does not usually require new land, as it can be installed on existing infrastructure
- Solar is a highly reliable technology at any scale
- There are low environmental impacts during construction and operation of solar electricity systems
- Solar generation can be easily added incrementally to match capacity increase needs – maximising the utilisation of investments.

<sup>34</sup> Currently in New Zealand solar is used mainly in residential domestic scale applications and a few individual industrial applications. It is not yet used for commercial-scale electricity generation.

## Benefits specific to electricity generation using marine resources

---

- Marine energy devices, particularly submarine tidal current turbines, are likely to have limited visual or noise impacts on humans
- Off-shore wave energy devices and tidal current devices may be compatible with some other activities such as marine reserves and marine farms (though they may compete with commercial or recreational fishing)
- Tidal energy is variable, but it is somewhat predictable – tidal heights are very predictable, but tidal currents are much less so due to interaction of ocean currents, wind effects and other factors. Cook Strait tidal currents are notably variable from theoretical predictions.



## 5. Policy B: Practical implications

### **B. Acknowledging the practical implications of achieving New Zealand's target for electricity generation from renewable resources**

#### **Policy B**

*Decision-makers shall have particular regard to the following matters:*

- a) maintenance of the generation output of existing renewable electricity generation activities can require protection of the assets, operational capacity and continued availability of the renewable energy resource; and*
- b) even minor reductions in the generation output of existing renewable electricity generation activities can cumulatively have significant adverse effects on national, regional and local renewable electricity generation output; and*
- c) meeting or exceeding the New Zealand Government's national target for the generation of electricity from renewable resources will require the significant development of renewable electricity generation activities.*

Policy B requires an understanding of the operational requirements of the existing renewable electricity generation activity assets, the location and associated operational capacity and the threats to existing generation activities and assets (e.g. minimum flow levels). Subparagraphs (a) and (b) emphasise the need to protect existing generation in order to achieve the renewable electricity target. While subparagraph (c) focuses on the new generation required to meet the renewable electricity target.

#### **Policy B**

- a) Maintenance of the generation output of existing renewable electricity generation activities can require protection of the assets, operational capacity and continued availability of the renewable energy resource**

Maintenance of the generation output of existing renewable electricity generation activities requires the protection of the energy source, the generation facility (power plant) and the operational process. Figure 24 illustrates this process.

*Figure 24 Electricity output process*

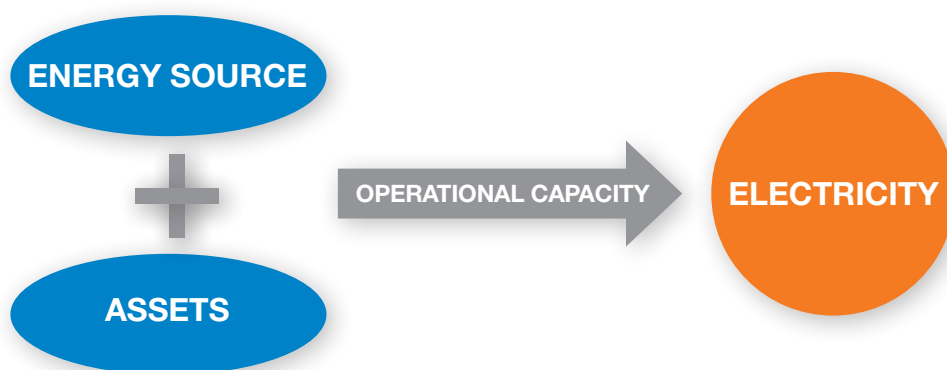

*(Source: EECA)*

A change to any one of these components or processes will alter the output of electricity. The assets refer to the things that enable the generation of electricity. Principally, this is physical generation items, such as turbines and hydro dams. However, it may also include other things required for the generation of electricity such as intellectual property. The operational capacity is the level of power that can be produced by the electricity generation facility within the operating constraints. For example, the operational capacity of a hydro scheme may be lower than its maximum theoretical capacity if it is limited to a maximum water flow rate that is less than the maximum that the turbines could make use of.

### **Policy B**

#### **b) Even minor reductions in the generation output of existing renewable electricity generation activities can cumulatively have significant adverse effects on national, regional, and local renewable electricity generation output**

While the impact of reducing electricity generation output by a relatively small amount at one existing station is minor, the cumulative effect of this occurring in multiple electricity generation facilities is significant.

#### **MOTUKAWA HYDRO SCHEME**

*The TrustPower-owned Motukawa hydro scheme (see Figure 25) generates electricity from the flow of water that is diverted from the Manganui River to Waitara River in Taranaki via a man-made storage lake. The difference in elevation between the two rivers is approximately 100 m. The hydro scheme has a total capacity of 5 MW and an average annual output of 22 GWh.*

*The hydro scheme has been supplying electricity since the 1930s. The scheme was re-consented in 2001 by the Taranaki Regional Council. In particular, the consent conditions relate to the rate at which water can be taken and discharged, lake levels and flows, and flora and fauna. These consent conditions alter both the quantity (and timing) of the energy source, and the allowable operating process. TrustPower has estimated that adhering to these consent conditions has reduced electricity output from the hydro scheme by 6-7% compared to operation under the previous set of conditions. This illustrates the potential for generation output reductions through a re-consenting process.*

*Policy B (b) directs decision-makers to take a wide view of effects on output by having particular regard, not only to any potential output reduction directly attributable to the relevant decision under consideration (whether a resource consent or proposed plan provision), but also to other existing generation output reductions, if any. This is to enable an understanding of the effect that cumulative reductions as a whole may have on the ability of existing generation to contribute to achieving the renewable electricity target.*

**Figure 25 Motukawa hydro-electricity scheme, Taranaki**



*(Photo courtesy of Trustpower)*

### **Policy B**

#### **c) Meeting or exceeding the New Zealand Government's national target for the generation of electricity from renewable resources will require the significant development of renewable electricity generation activities**

A significant amount of new renewable electricity generation capacity from a range of resources will need to be built (replacing some existing fossil fuel electricity generation) in order to reach the renewable electricity target. Section 3 of this guide presents information on the renewable electricity target.

## 6. Policy C: Practical constraints

### **C. Acknowledging the practical constraints associated with the development, operation, maintenance and upgrading of new and existing renewable electricity generation activities**

#### **Policy C1**

*Decision-makers shall have particular regard to the following matters:*

- a) the need to locate the renewable electricity generation activity where the renewable energy resource is available;*
- b) logistical or technical practicalities associated with developing, upgrading, operating or maintaining the renewable electricity generation activity;*
- c) the location of existing structures and infrastructure including, but not limited to, roads, navigation and telecommunication structures and facilities, the distribution network and the national grid in relation to the renewable electricity generation activity, and the need to connect renewable electricity generation activity to the national grid;*
- d) designing measures which allow operational requirements to complement and provide for mitigation opportunities; and*
- e) adaptive management measures.*

#### **Policy C2**

*When considering any residual environmental effects of renewable electricity generation activities that cannot be avoided, remedied or mitigated, decision-makers shall have regard to offsetting measures or environmental compensation including measures or compensation which benefit the local environment and community affected.*

Policy C requires an understanding of the practical constraints associated with renewable electricity generation activities. Practical constraints can limit their ability to avoid, remedy or mitigate adverse effects. Section 3 of this document identifies operational and maintenance considerations specific to renewable electricity generation activities.

#### **Policy C1**

##### ***a) The need to locate the renewable electricity generation activity where the renewable energy resource is available***

Renewable electricity generation must be located where the resource is available. In order to be viable, wind farms must be located in locations where the wind is consistently strong, which is often on elevated sites. Biomass plants are best located near the source of the biomass, because of the costs of transporting biomass long distances. Potential locations of geothermal power stations are particularly limited as they must be near the geothermal energy resource. In New Zealand high-temperature geothermal resources are limited to the Taupō Volcanic Zone and Ngāwhā in Northland. Hydro-electricity power schemes must be located where the existing elevation or natural fall is sufficient to be utilised to produce electricity and the catchment area has sufficient rainfall.

### **Policy C1**

#### ***b) Logistical or technical practicalities associated with developing, upgrading, operating or maintaining the renewable electricity generation activity***

There can be practical constraints associated with logistical and technical practicalities to developing, operating, maintaining and upgrading renewable electricity generation activities. These practicalities can present challenges to new and existing activities being consented unless they are specifically recognised by decision-makers: longer consent lapse periods are just one example of how some logistical constraints can be acknowledged and accommodated.

Logistical or technical practicalities that may constrain renewable electricity generation activities include:

- suitable transportation routes and access: for example, the Project West Wind involved the construction of a wharf and strengthening of bridges to transport turbine components to the construction site to avoid using the local road network which could not accommodate heavy vehicles
- changing technology and international availability of technology; for example, wind turbine models continue to develop over time
- availability of infrastructure and skilled workers; for example, the limited availability of drilling rigs and teams can impact on the construction timeframe for a geothermal power station
- the need to shut down or restrict access to water bodies in order to dredge sediment build-up in hydro storage lakes.

### **Policy C1**

#### ***c) The location of existing structures and infrastructure including, but not limited to, roads, navigation and telecommunication structures and facilities, the distribution network and the national grid in relation to the renewable electricity generation activity, and the need to connect renewable electricity generation activity to the national grid***

Electricity generation facilities are dependent on access to a range of existing infrastructure such as access to roads which are important to enable machinery, construction materials and plant to be brought to the site. Proximity to a connection point to the distribution or transmission network is also necessary. This means that some locations with extremely good renewable energy resources may be too costly and not suitable for renewable electricity generation because of the lack of supporting infrastructure. Selecting locations is also dependent on the combination of the locations of high demand and whether existing transmission and distribution networks have the capacity to transmit additional electricity.

#### **TAUHARA STAGE II GEOTHERMAL**

*Contact Energy has received resource consent for Stage II of the Tauhara Geothermal development. Stage II will consist of a 250 MW electricity generating station, fuelled by the heat energy of the Tauhara steam field. Tauhara is North-East of Taupō. The location of the power station is controlled by a number of factors:*

- *located on the steamfield (i.e. close to the renewable energy resource)*
- *close to suitable grid transmission lines*
- *distance away from Taupō township and rural residences*
- *good topography for construction of power station*
- *good road access*
- *distance from seismic faults*
- *good elevation for air discharge dispersion*
- *compatible adjacent land uses*
- *not being visible from Lake Taupō-shore.*

## Policy C1

### d) Designing measures which allow operational requirements to complement and provide for mitigation opportunities

Mitigation of adverse effects from renewable electricity generation can in some cases be provided within the operating requirements of the scheme.

#### WAITAKI HYDRO-ELECTRICITY SCHEME

*The Waitaki hydro scheme consists of eight electricity generation facilities on the Waitaki River, North of Dunedin with ownership split between Meridian Energy and Genesis Energy. The largest generation facility in the scheme is Benmore (see Figure 26), with a capacity of 540 MW.*

*The Waitaki scheme involved the flooding of a number of braided rivers, and the flow of other rivers has been diverted and reduced. To help offset the effects on the rivers, a conservation programme was established in partnership with the Department of Conservation. This programme established over 100 ha of wetlands, some with predator-proof fences to protect the abundant native wildlife. Salmon, trout, and eels are supported with various measures. Consent conditions require extra river flows to be released at pre-notified times to allow for recreational use such as kayaking.*

*Figure 26 Benmore power station, Waitaki hydro-electricity scheme*



*(Photo courtesy of Meridian Energy)*

## Policy C1

### e) Adaptive management measures

An adaptive management approach is consistent with precautionary management as it enables informed decisions to be made regarding future mitigation of adverse effects that may arise over time. An adaptive management approach allows development to proceed in situations where adverse effects are uncertain or unknown, such as when large and complex ecological systems are involved or new technologies or activities are being proposed. It requires disclosure of new or changing information about the ecosystems so that steps can be taken before significant adverse effects eventuate. It uses provisions or conditions that require a reduction or deterrence of development if monitoring results are negative. But with these in place, it allows development to proceed once environmental gateways have been passed. Measures include management plans, monitoring programmes, condition reviews, staged development, financial contributions, environmental audits, environmental standards, community participation and co-regulation between the industry applicant and the council consent authority.

Adaptive management has been applied to renewable electricity generation facilities where there is a degree of uncertainty regarding environmental effects (such as land subsidence in the case of geothermal electricity generation) and allows for issues that may arise over time to be addressed in a flexible and comprehensive manner.

## NGATAMARIKI GEOTHERMAL

Ngatamariki geothermal power station is an 82 MW geothermal generation facility currently under construction near Taupō, led by Mighty River Power and Tauhara North No. 2 Trust. The plant will provide baseload electricity to the national grid.

Operation of geothermal electricity generation facilities provides further understanding of the characteristics of the steamfield, so adaptive management is commonly used in geothermal developments. The operators of Ngatamariki will extensively monitor the geothermal resource and land overlying it for various factors, including reservoir temperature and pressure. This monitoring will feed into regularly updated models of the steamfield. These models will help the operators decide the best methods of operation, such as where to reinject fluid.

### Policy C2

**When considering any residual environmental effects of renewable electricity generation activities that cannot be avoided, remedied or mitigated, decision-makers shall have regard to offsetting measures or environmental compensation including measures or compensation which benefit the local environment and community affected**

The Implementation Guide for the NPS REG prepared by the Ministry for the Environment (p19) explains the context for offset measures and environmental compensation. Offsetting and environmental compensation can provide alternative benefits to an affected community to counterbalance adverse effects from renewable electricity generation activities. Examples where these have formed part of resource consent decisions include the Tongariro hydroelectricity scheme and the Wairakei geothermal power station (see case studies below).

## TONGARIRO HYDRO-ELECTRICITY SCHEME

Genesis Energy owns and operates the Tongariro power scheme ('TPS') shown in Figure 27. The TPS encompasses three power stations – Tokaanu (240 MW), Rangipo (120 MW) and Mangaio (1.8 MW) – and uses a series of lakes, canals and tunnels to divert water into the three power stations from an extensive catchment area extending over 2400 km<sup>2</sup>. There are two main diversions: the Eastern Diversion that diverts waters from the Moawhango and Wahianoa headwaters into the Tongariro River then ultimately into Lake Rotoaira; and the Western Diversion that diverts waters from the headwaters of the Whanganui River into Lake Rotoaira.

As part of re-consenting the TPS in 2002, Genesis Energy was required to consider the impact of hydro generation activities on the population of whio (Blue Duck) on the Tongariro River. After detailed ecological studies and extensive consultation, multiple stakeholders – including the Department of Conservation and Forest and Bird – agreed that adverse ecological effects on the upper Tongariro River, which is susceptible to volcanic events, would be mitigated by enhancing whio habitat on the Western Diversion. This was achieved through a mitigation package including minimum flows and the establishment of the Central North Island Blue Duck Charitable Trust. The minimum flows were designed to improve whio habitat. The Trust is focused on enhancing existing and new whio populations in the central North Island, primarily through predator control.

The success of this mitigation package (a 15% increase in the national population) has led to Genesis and the Department of Conservation partnering to extend support to whio populations elsewhere in New Zealand through the Genesis Energy National Whio Recovery Programme.

Figure 27 Tokaanu power station, Tongariro hydro-electricity scheme



(Photo courtesy of Genesis Energy)

## WAIRAKEI GEOTHERMAL POWER STATION

Contact Energy owns and operates the Wairakei geothermal power station, which is shown in Figure 28. It has been producing electricity from geothermal fluid for more than 50 years. It was the world's first large-scale producer of electricity from wet steam.

The introduction of the RMA required that all existing operations seek consents under the RMA for their operation by 2001.

On re-consenting, one of the measures the company undertook to offset the adverse effects of the operation of the power station was the establishment of the Wairakei Environment Mitigation Charitable Trust to facilitate the enhancement, protection and management of a variety of geothermal and natural resources characteristics located within the Waikato Regional Council's boundary. Funding is allocated to research for the protection and enhancement of: the variety of the geothermal characteristics with 'Protected Geothermal Systems' as defined in the Waikato Regional Plan and other geothermal systems; and Aquatic habitat and amenity (including rivers, lakes and wetlands), water quality or fishery values in the upper Waikato River catchment area (Lake Taupō outlet to Ohakuri Dam).

Funds have been distributed to a range of environmental enhancement activities and research, including control of pest plants in geothermal areas, restoration of geothermal and freshwater wetlands, and research into geothermal biodiversity.

Figure 28 Wairakei geothermal power station, Taupō



(Photos courtesy of GNS Science)

## Hydro-electricity generation facilities

---

The size of the power station and associated infrastructure is site specific and dictated by the watercourse, and the complexity of the water flow. In many cases, the biggest part of the project will be a dam; however for schemes like Manapouri (where water flows from Lake Manapouri to the sea via the Manapouri hydro-electric power station and Doubtful Sound), long tunnels are necessary. The turbine house is situated at the foot of the penstock, usually at the base of the dam. Large stations that are connected to the grid will also generally require an area of flat land to be covered in gravel and used as a switchyard, where all of the transformers and circuit breakers are situated.

Many thousands of cubic metres of concrete (often in difficult, mountainous terrain) are usually required for large hydro-electricity schemes. The turbine, generator, and penstock are generally designed and manufactured 'on demand' and the performance characteristics of the equipment are governed by the inherent physical geography of the scheme.

Practical constraints for hydro generation include:

- a significant fall and a sufficient water flow rate
- topography and geology that can accommodate the required structures
- a source of water that will provide a reasonably constant supply
- sufficient depth of water at the point at which the water is taken from the watercourse
- proximity to grid connection
- managing hydro inflows and storage on a daily, weekly and annual basis.

## Geothermal electricity generation facilities

---

Practical constraints associated with geothermal electricity generation may result from the need to access geothermal fluids and heat from various underground locations that require extensive pipework over several square kilometres of land. Multiple land uses may be able to be accommodated, with farming and forestry being common land uses in the area covered by the steamfield fluid collection and disposal system. The land area for the generation facility is relatively small – about the size of a sports field.

The key constraining factor for geothermal generation is that current technology and economics restricts electricity generation from geothermal resources to high-temperature geothermal reservoirs, which are only located in the Waikato, Bay of Plenty and Northland regions.

Other key constraints are managing extraction, discharges and reinjection, proximity to the grid and available grid capacity.

## Wind farms

---

There are a number of practical considerations required to ensure wind farms operate efficiently. Practical constraints for wind farms include:

- strong and consistent winds, which can sometimes be located in or near sensitive noise environments
- adequate spacing between turbines to provide adequate separation between turbines to lessen energy loss through wind shadowing from upwind machines
- the ability to transmit the electricity from where it is generated to where it may be used (i.e. proximity to a suitable transmission line or substation)
- the capacity of the local electricity distribution grid (for small- and community-scale wind farms)
- open land without current or future obstacles to the wind flow
- good access for wind farm construction and maintenance
- suitable geology for access tracks and turbine foundations
- the ability to source wind turbine technology that suits the site conditions
- the consistency and strength of the wind (e.g. on ridgelines rather than behind hills with limited turbulence).



Considered together, these requirements mean that wind farms are usually located in high country, and may be a considerable distance from the nearest grid connection.

The lifespan of wind turbines is expected to be around 25 years, meaning from around 2020 existing New Zealand wind farms are likely to begin replacing their turbines.

The new turbines could be significantly different from the original turbines, thus changing the environmental effects. In the 1990s, turbines installed in New Zealand were less than 1 MW per turbine, whereas modern turbines are 2 - 3 MW. Modern turbines typically have taller towers and longer blades. Stages I and II of the Tararua wind farm (1999 and 2004) used 0.66 MW turbines with 40 m towers and 24 m blades, whereas Stage III, completed in 2007, used 3 MW turbines with 65 m towers and 45 m blades.

## **Biomass electricity generation**

---

Constraining factors for biomass generation include:

- land area to generate feedstock
- proximity to and availability of feedstock – biomass is a low-value, high-volume commodity that significantly increases in cost with even short transport distances
- proximity to landfill gas source – electricity generation plants need to be located at or near the landfill site to reduce the need to pipe the gas over long distances
- proximity to grid connection – a plant needs to be located close to existing grid infrastructure with the capacity to accept the proposed generation capacity
- availability of suitable technology for the fuel type.

## **Solar electricity generation**

---

- Size and space: Single PV panels vary in size, depending on output, with larger panels around 1.6 m × 1 m. This sized panel generates around 250 W at peak sunlight levels. They may be combined in an array to deliver the required power output. For example, an array of 8,250 W peak panels will produce 2 kW peak and occupy around 13 square metres of roof space. Space for an inverter – to convert the direct current (DC) electricity the panels generate into 50 Hz AC (alternating current) – is also required. A domestic inverter will generally take up as much space as a domestic fuse-box, whereas a large solar array on the roof of a commercial building will require a kiosk substation, about the size of a golf cart
- Solar arrays are best suited to locations of strong, consistent sunlight
- There are no key geographic factors that prevent the use of PV systems other than a preference to be north facing, and to avoid shading from trees and other structures
- To be most efficient, they should be inclined at an angle of 20-40° (depending on latitude) and orientated facing due north. Where this is not possible, to function well, they should be inclined at between 10-60° and orientated facing from east to west (within 90° of due north)
- PV cells do not generate electricity at night, and they are less effective in cloudy weather, meaning that if utilised as a stand-alone system, either a storage system or complementary power system is usually required.

## **Marine electricity generation facilities**

---

All marine energy electricity generation projects will require a submarine cable, which will emerge from the sea and connect to an onshore transmission or distribution network or directly to a consumer, via switchgear. This could involve a small building, or some outdoor electrical equipment and transmission lines from the coast to the connection point.

Constraining factors associated with marine energy generation include:

- proximity to on-shore grid connection
- speed and height of tidal currents and sea levels
- survivability in severe weather conditions
- cost of maintenance
- environmental impact on seabed and shoreline.

## 7. Policy D: Managing reverse sensitivity effects

### **D. Managing reverse sensitivity effects on renewable electricity generation activities**

#### **Policy D**

*Decision-makers shall, to the extent reasonably possible, manage activities to avoid reverse sensitivity effects on consented and on existing renewable electricity generation activities.*

Policy D requires an understanding of reverse sensitivity effects on consented and existing renewable electricity generation activities. Reverse sensitivity effects arise when new sensitive activities are established in the vicinity of existing lawful activities and, following their establishment, introduce a demand for the pre-existing activity to alter its operation to avoid, remedy or mitigate effects on the new activity. Reverse sensitivity effects arising in relation to the operation of renewable electricity generation activities can lead to reduction in electricity output.

#### **MANAGING REVERSE SENSITIVITY EFFECTS ON THE WAIRAKEI-TAUHARA GEOTHERMAL SYSTEM**

*Part of the Wairakei-Tauhara geothermal system underlies the town of Taupō. The system is classified as a Development Geothermal System in the relevant regional plan and there are four geothermal power stations on it, with another under construction and another consented. In recent years, the Taupō area has been under significant development pressure to accommodate the demand for expansion of the urban area of Taupō and new rural-residential lifestyle developments near the town. New residential developments in the vicinity of geothermal power stations have the potential to create reverse sensitivity effects. For instance:*

- Geothermal developments require new production and reinjection/injection wells to be drilled to enable their ongoing operation. Geothermal well-drilling is a 24 hour a day, 7 day a week operation and produces noise levels that are incompatible with maintenance of residential amenity in the vicinity;*
- Subsurface pressure changes on a geothermal system that is subject to large-scale developments can create or exacerbate hazards (e.g. subsidence and other land deformation, increases in heat flow through the ground).*

*Taupō District Council has recognised that reverse sensitivity effects on geothermal power development on the Wairakei-Tauhara geothermal system need to be managed. Initially reverse sensitivity was addressed in growth strategy documents prepared under the Local Government Act 2002 with provision for the East Taupō arterial highway to act as an urban fence, separating the town from the balance of the geothermal system. This was followed by district plan changes putting in place policies and rules discouraging establishment or expansion of incompatible activities on the geothermal system east of the highway.*

*Reverse sensitivity effects have also been addressed by land developers registering encumbrances on the title of the land incorporating 'no complaint' covenants (in relation to noise) and requirements for house designs to incorporate provision for potential hazards.*

## 8. Policy F: Small and community-scale electricity generation

### F. Incorporating provisions for small and community-scale renewable electricity generation activities into regional policy statement and regional and district plans

#### Policy F

*As part of giving effect to Policies E1 to E4, regional policy statement and regional and district plans shall include objectives, policies, and methods (including rules within plans) to provide for the development, operation, maintenance and upgrading of small and community-scale distributed generation from any renewable energy source to the extent applicable to the region or district.*

Small and community-scale embedded electricity generation is the generation of electricity that is either used directly by the producer or exported to the local distribution network.

There is a wide range of small and community-scale electricity generation occurring in New Zealand. This ranges in size from a household with a single solar panel, through to hydro or wind electricity generation schemes that can be over 5 MW.

Figure 29 shows the 0.75 MW Weld Cone wind farm in Marlborough and Figure 30 shows the 2 MW Talla Burn hydro scheme in Central Otago which are both connected to the local distribution networks.

#### WELD CONE WIND FARM

*The Weld Cone wind farm (see Figure 29) is a three-turbine wind farm in Marlborough owned and operated by independent wind farm generator Energy3. Weld Cone was commissioned in February 2010 and supplies electricity into the local Marlborough lines network. The wind farm has a total capacity of 0.75 MW. It generates enough electricity to meet the needs of around 350-400 homes. It uses second-hand, imported wind turbines that are thoroughly refurbished before being put back to use. Each turbine has a capacity of 0.25 MW.*

*Energy3 also operates the four-turbine, 1 MW Lulworth wind farm in Marlborough which is a partnership with the Lulworth Family Farm Trust, and a prototype 100 kW single-turbine near Southbridge in Canterbury.*

*Figure 29 Weld Cone wind farm, Marlborough*



*(Photo courtesy of Energy3)*

Small-scale hydro schemes that produce electricity directly for a household or farm are often as small as half a kilowatt. Another common form of embedded generation is co-generation, whereby both heat and electricity are generated together. For example, a timber mill may burn sawdust and off-cuts to generate heat for timber-drying kilns, but then use any excess steam to generate electricity that can be used by the mill or exported to the distribution network.

### TALLA BURN HYDRO – THE PAUL WILSON STATION

The Paul Wilson station is a 2 MW hydro scheme (Figure 30) on a remote 70,000 acre high country station in Central Otago. Sited on a 19th century gold-mining race on the Talla Burn, a tributary of the Clutha River, the station is generating 13 GWh of electricity a year, powering 1,000 homes in the district.

Local retailer Pulse Energy buys the electricity which is supplied to the grid via a 21 km transmission line. The project was initiated and developed by the local Wilson and Hore families. As well as being locally owned and operated, the project gained strong community buy-in: the consenting phase took only a year. With an indefinite lifespan and secure supply, the families describe the project as an example of stewardship rather than ownership.

Figure 30 Talla Burn hydro scheme, Central Otago



(Photo courtesy of Paul Wilson Station)

There are a number of benefits of small and community-scale generation:

- The amount of electricity lost during transport through transmission wires is less due to the proximity to the electricity consumers
- In remote areas, the cost of connection to the grid can be more expensive than the cost of small-scale electricity generation equipment, so an off-grid solution (which may involve renewables) can be more cost effective
- Embedding generation (connecting to a local line) can sometimes provide a lower cost connection option when the nearest national grid transmission line might be a significant distance away. This is simply a potential cost benefit, and will depend on specific circumstances of generation size and location of electricity connection options.

### Further information on distributed generation

#### SEANZ

[www.seanz.org.nz](http://www.seanz.org.nz)

#### EECA guidance document on domestic scale distributed generation

[www.eeca.govt.nz/sites/all/files/dg-guidance-for-local-govt-may-2010.pdf](http://www.eeca.govt.nz/sites/all/files/dg-guidance-for-local-govt-may-2010.pdf)

#### NZGA report on geothermal distributed energy

[www.nzgeothermal.org.nz/publications/Reports/DistributedEnergyReportFinal23June08.pdf](http://www.nzgeothermal.org.nz/publications/Reports/DistributedEnergyReportFinal23June08.pdf)

## 9. Policy G: Enabling identification of renewable electricity generation possibilities

### G. Enabling identification of renewable electricity generation possibilities

#### Policy G

*Regional policy statements and regional and district plans shall include objectives, policies, and methods (including rules within plans) to provide for activities associated with the investigation, identification and assessment of potential sites and energy sources for renewable electricity generation by existing and prospective generators.*

Policy G requires an understanding of the key activities that are generally carried out to identify the renewable energy resources and help confirm the feasibility of renewable electricity projects.

#### Hydro-electric feasibility investigations

- Water flow rate measurements are required to form a reliable estimate of available power. Long term inflow measurements are required to estimate potential generation at a site. Long-term measurements (greater than a decade) are generally not available, and so these may need to be extrapolated from the size of the catchment and previous years' rainfall data
- Geotechnical studies for suitable dam locations are necessary – not only for concrete dams, but also to avoid mudslides and hill slips in earth dams. This often involves drilling, which would be done by a drilling unit on a vehicle (a tractor, an excavator, a trailer or a purpose-built vehicle). The drilling requires site access and water in-take and discharge, and may result in noise and subsidence.

#### Geothermal feasibility investigations

- Prospective locations are identified by collating existing scientific data and identifying anomalies in the earth's crust
- Developers may undertake further scientific surveys using the latest techniques
- Exploration drilling may be carried out. Figure 31 shows a geothermal drilling rig
- After prospective well locations are identified and wells are designed, wells are drilled to establish sub-surface geology and in-situ fluid type and temperature
- After prospective locations are identified wells are drilled, including exploration wells (where temperatures and rock structure are evaluated). With this information geophysicists map the area in 3D and provide a conceptual model of the geothermal resource size. Geotechnical studies are also required to assess subsidence and the effect on surface features.

Figure 31 Geothermal drilling rig



(Photo courtesy of GNS Science)

## Wind farm feasibility investigations

---

- Wind monitoring: Identifying consistent and strong winds may be done from meteorological data, but obtaining site-specific data involves erecting wind monitoring instruments. Generally, prospective locations are chosen on exposed, often elevated, land. It is necessary to erect several wind monitoring towers to measure wind speed and direction over a period of at least a year, generally longer. The wind towers are typically at turbine hub height (about 80-100 m above ground level for existing turbines). Figure 32 illustrates a typical wind monitoring mast.
- Geotechnical investigations allow foundation design and steepness of cuts and fills associated with wind farm road design.

Figure 32 Wind monitoring mast



(Photo courtesy of NZWEA)

## Solar array feasibility investigations

---

The feasibility investigation for a solar array in a New Zealand context is relatively simple, and comprises:

- measuring the insolation (average solar radiation intensity or 'irradiance', in kilowatt hours per square metre, per day – kW.h/m<sup>2</sup>.d). This may be measured with a small pyranometer, or estimated based on local weather records and the location latitude
- structural assessment of building roofs to determine whether they can bear the weight of the panels
- characteristic weather patterns, including the proportion of cloudy days, and probability of extreme weather events that could damage the panels, such as salt spray, debris from strong winds, heavy snow, or hail
- consideration of shadows and ability to achieve optimum panel placement and angle (e.g. the southern face of a sloping roof is likely to be shadowed during winter)
- consultation with the local distribution network and the national grid system operator for installations greater than 1 MW.

## 10. Glossary

**Baseload generation** – lowest cost electricity generation facilities designed to operate continuously to supply the minimum electricity requirements of the country or region.

**Capacity factor** – the ratio of actual generation output over a year compared to what the plant would have generated if it had operated at full rated capacity for that year. Capacity factors vary significantly between technologies, with geothermal tending to be quite high, and wind somewhat lower (although wind capacity factors in New Zealand are significantly higher than much of the rest of the world). Capacity factors also vary within a technology (e.g. from one wind farm site to another), and will vary year to year even for a particular wind farm site, pending climatic conditions. The average capacity factors generally assumed for each renewable electricity generation resource type are to a large extent dependent on availability of the resource, for instance, how much the wind blows or the river flows.

**Carbon dioxide equivalent (CO<sub>2</sub>e)** – a measure of greenhouse gas emissions that accounts for differences in the global warming potential of different gases by calculating the amount of CO<sub>2</sub> that would produce equivalent warming over a standard length of time (typically a 100 year time horizon is used). CO<sub>2</sub>e is measured by mass, usually in tonnes.

**Co-generation** – the use of two or more forms of energy from a single energy source such as an electricity-generating facility that produces electricity and a form of useful thermal energy such as heat or steam for industrial or commercial heating and cooling purposes.

**Connection points** – a power station must connect to a distribution network or the national grid if it is to export the electricity to other consumers. The point of connection usually involves additional electrical equipment, such as an electricity transformer. The national grid has approximately 200 grid exit points where the national grid connects to direct users and distribution networks. Consumers must connect either to the distribution network or the national grid to access electricity. Direct connection to the national grid is only suitable for very large users near the national grid transmission lines.

**Distribution network** – an electricity distributor's lines and associated equipment used for the conveyance of electricity on lines other than lines that are part of the national grid. The distribution networks are operated by distribution companies (also referred to as lines companies) and operate at a lower voltage than the national grid and provide the final connection to the majority of consumers. These include the overhead power lines seen in suburbs.

**(Electricity generation) operational capacity** – the theoretical maximum power that can be produced by an electricity generation facility, typically measured in megawatts (MW). The actual power produced is often less than the maximum due to variability in the resource (wind, hydro and solar) and a capacity factor is the average proportion of maximum power that is actually realised over time.

**Frequency keeping** – electricity generation must be continuously matched to demand on a moment-to-moment basis to ensure that the entire electricity system is maintained in a stable and secure state. For example, even a small increase in demand, without a corresponding increase in supply, will cause the system frequency to fall as rotating generators give up stored energy and slow down. Frequency keeping involves the use of generators able to correct relatively normal changes in frequency.

**Generation output** – amount of electricity produced, which is the power multiplied by time, and is typically measured in kilowatt hours (kWh) or megawatt hours (MWh) or gigawatt hours (GWh).

**National grid** – the lines and associated equipment used or owned by Transpower to convey electricity. The national grid is operated at a higher voltage than distribution networks to reduce electricity losses. The national grid feeds the distribution networks as well as directly supplying electricity to a few large electricity users. This includes the power lines on large lattice towers through the country side.

**New Zealand's electricity generation** – the total amount of electricity that is exported to distribution networks or the national grid and electricity that is used directly by the generator.

**Peak demand** – the peak (maximum) consumption of electricity (averaged over a half-hour period) recorded during a day. Peak demand is also measured over any given time (e.g. a week, or year).

**Peak generation** – flexible generation facilities that only run during periods of high demand. Peaking plants are usually more expensive to run than baseload generation but are only required to operate for short periods of time when demand is high, thereby providing important security of supply.

**Renewable electricity generation** – generation of electricity from solar, wind, hydro-electricity, geothermal, biomass, tidal, wave, or ocean current energy sources. These energy sources are not finite, and generally produce less greenhouse gas emissions than fossil fuel energy sources.

**Renewable generation electricity generation activities** – the construction, operation and maintenance of structures associated with renewable electricity generation. This includes small and community-scale distributed renewable generation activities and the system of electricity conveyance required to convey electricity to the distribution network and/or the national grid and electricity storage technologies associated with renewable electricity.<sup>35</sup>

**Security of electricity supply (security of supply)** – the ability to maintain continuous electricity supply to consumers with resilience to shocks and changes. From a generation perspective, security of supply is achieved with sufficient electricity generation capacity and diverse sources and locations of electricity generation.

**Small- and community-scale distributed electricity generation** – renewable electricity generation for the purpose of using electricity on a particular site, or supplying an immediate community, or connecting into the distribution network.<sup>36</sup> This differs from most large generation, which connects to the national grid.

**Transmission losses** – losses incurred by TransPower and local distribution (lines) companies in conveying electricity from the site of generation to the consumer. Losses result mainly from transformer or other losses on the network.

<sup>35</sup> From the National Policy Statement for Renewable Electricity Generation.

<sup>36</sup> From the National Policy Statement for Renewable Electricity Generation.



## 11. References

Board of Inquiry Transmission Gully Plan Change (2011) *Final Decision and Report of the Board of Inquiry into the New Zealand Transport Agency Transmission Gully Plan Change Request*. Produced under Section 149R of the Resource Management Act 1991. Available online at [www.epa.govt.nz/Publications/PCTG%20Final%20Decision%20Report.pdf](http://www.epa.govt.nz/Publications/PCTG%20Final%20Decision%20Report.pdf)

---

Concept Consulting Group (2009) *Renewable Generation and Security of Supply*. Prepared for the Energy Efficiency and Conservation Authority. Available online at [www.eeca.govt.nz/resource/renewable-generation-and-security-supply](http://www.eeca.govt.nz/resource/renewable-generation-and-security-supply)

---

East Harbour Management Services Limited (2008) *Distributed Energy Roles for Geothermal Resources in New Zealand*. Prepared for the New Zealand Geothermal Association. Available online at [www.nzgeothermal.org.nz/publications/Reports/DistributedEnergyReportFinal23June08.pdf](http://www.nzgeothermal.org.nz/publications/Reports/DistributedEnergyReportFinal23June08.pdf)

---

Energy Efficiency and Conservation Authority (2010) *Domestic scale distributed generation: Guidance for local government*. Available online at [www.eeca.govt.nz/sites/all/files/dg-guidance-for-local-govt-may-2010.pdf](http://www.eeca.govt.nz/sites/all/files/dg-guidance-for-local-govt-may-2010.pdf)

---

Energy Efficiency and Conservation Authority (2010) *Power from the People: A Guide to Micro-generation*. Available online at [www.eeca.govt.nz/resource/power-people-guide-microgeneration](http://www.eeca.govt.nz/resource/power-people-guide-microgeneration)

---

Koorey, Kevin J., & Fernando, Ajith D (2010) *Concurrent Land Use in Geothermal Steamfield Developments*, Proceedings World Geothermal Congress 2010.

---

Ministry for the Environment (2008). *National Policy Statement on Electricity Transmission 2008*. Available online at [www.mfe.govt.nz/publications/rma/nps-electricity-transmission-mar08/index.html](http://www.mfe.govt.nz/publications/rma/nps-electricity-transmission-mar08/index.html)

---

Ministry for the Environment (2011). *National Policy Statement for Renewable Electricity Generation 2011*. Available online at [www.mfe.govt.nz/publications/rma/nps-renewable-electricity-generation-2011/docs/nps-reg-2011.pdf](http://www.mfe.govt.nz/publications/rma/nps-renewable-electricity-generation-2011/docs/nps-reg-2011.pdf)

---

Ministry for the Environment (2011). *National Policy Statement for Renewable Electricity Generation 2011 Implementation Guide*. Available online at [www.mfe.govt.nz/publications/rma/nps-renewable-electricity-generation-guide-2011/](http://www.mfe.govt.nz/publications/rma/nps-renewable-electricity-generation-guide-2011/)

---

Ministry for the Environment (2012). *New Zealand's Greenhouse Gas Inventory 1990–2010*. Available online at [www.mfe.govt.nz/publications/climate/greenhouse-gas-inventory-2012/greenhouse-gas-inventory-2012.pdf](http://www.mfe.govt.nz/publications/climate/greenhouse-gas-inventory-2012/greenhouse-gas-inventory-2012.pdf)

---

Ministry of Economic Development (2010) *New Zealand's Energy Outlook 2010 Reference Scenario*. Available online at [www.med.govt.nz](http://www.med.govt.nz)

---

Ministry of Economic Development (2011) *New Zealand's Energy Outlook 2011 Reference Scenario*. Available online at [www.med.govt.nz](http://www.med.govt.nz)

---

Ministry of Economic Development (2012) *New Zealand Energy Data File 2011 Calendar Year*. Available online at [www.med.govt.nz](http://www.med.govt.nz)

---

National Institute of Water and Atmospheric Research (2010) *New Zealand's EnergyScape™*. Available online at [www.niwa.co.nz](http://www.niwa.co.nz)

---

New Zealand Government (2011) *The New Zealand Energy Strategy 2011–2021: Developing our Energy Potential and the New Zealand Energy Efficiency and Conservation Strategy*. Available online at: [www.med.govt.nz/energy-strategy](http://www.med.govt.nz/energy-strategy)

---

New Zealand Wind Energy Association (2012) *Wind Energy 2030: The Growing Role for Wind Energy in New Zealand's Electricity System*. Available online at [www.windenergy.org.nz/resources/resources/271-wind-energy-2030-report](http://www.windenergy.org.nz/resources/resources/271-wind-energy-2030-report)

---

Oldham, K. (2008). *Reversibility of Renewable Energy Developments*. Available online at [www.mfe.govt.nz/rma/central/nps/generation/submissions/13-spx-attachment.pdf](http://www.mfe.govt.nz/rma/central/nps/generation/submissions/13-spx-attachment.pdf)

---

PB New Zealand LTD (2009) *Coal Prices and Availability Study*. Prepared for the Electricity Commission.

---

Power Projects Limited (2008) *The Development of Marine Energy in New Zealand*. Prepared for the Energy Efficiency and Conservation Authority and the Wellington Regional Council. Available online at [www.eeca.govt.nz/sites/all/files/marine-energy-in-nz-jun-08.pdf](http://www.eeca.govt.nz/sites/all/files/marine-energy-in-nz-jun-08.pdf)

---

Sinclair Knight Merz (2006–2008) *Regional Renewable Energy Assessments*. Prepared for the Energy Efficiency and Conservation Authority. Available online at [www.eeca.govt.nz/central-and-local-government/local-government/renewable-energy-planning-resources](http://www.eeca.govt.nz/central-and-local-government/local-government/renewable-energy-planning-resources)

---



Energy Efficiency and  
Conservation Authority  
Te Tari Tiaki Pūngao

Level 8 · 44 The Terrace · PO Box 388 · Wellington · New Zealand

P: +64 4 470 2200 · F: +64 4 499 5330

[www.eeca.govt.nz](http://www.eeca.govt.nz)

[New Zealand](http://www.newzealand.govt.nz) Government



EECA, Energy Efficiency and Conservation Authority, own the intellectual property rights in our trade marks and copyright featured in these guidelines.

© EECA Energy Efficiency and Conservation Authority 2013.

FEBRUARY 2013/EEC2721